

Superseded



As of August 19th, 1996 the Ethernet Consortium Clause # 28 Auto Negotiation State Machine Base Page Exchange Conformance Test Suite version 0.5 has been superseded by the release of the Auto Negotiation State Machine Base Page Exchange Conformance Test Suite version 1.0. This document along with earlier versions, are available on the Ethernet Consortium test suite archive page.

Please refer to the following site for both current and superseded test suites:

<http://www.iol.unh.edu/testsuites/ethernet/archive.html>

IEEE 802.3u Auto-Negotiation Conformance Tests

Table of Contents

Transmitted FLP Burst Composition

- 1.28 Separation of FLP Bursts
- 2.28 Internal Separation of FLP Bursts
- 3.28 Number of Pulses in a Burst
- 4.28 NLP Compliance

Transmitted Link Code Word (Base Page) Encoding

- 5.28 Transmitted Selector Field Combination
- 6.28 Transmitted Technology Ability Field
- 7.28 Remote Fault, Acknowledge, and Next Page Bits

FLP Burst Reception

- 8.28 Acknowledge Bit
- 9.28 Identification of Link Partner as Auto-Negotiation Able
- 10.28 Refusal of Incomplete FLPs
- 11.28 Acceptance of Long FLPs
- 12.28 Range of NLP Timer
- 13.28 Range of FLP Pulse Timer
- 14.28 Range of Data Detect Timer
- 15.28 Next Page Bit
- 16.28 Technology Ability Field Reserved Bits
- 17.28 Selector Field Reserved Combinations

Establishing a Link

- 18.28 Complete Acknowledge
- 19.28 Parallel Detection of 10Base-T Devices
- 20.28 Parallel Detection of 100Base-TX Devices
- 21.28 Parallel Detection of 100Base-T4 Devices
- 22.28 Priority Resolution Function
- 23.28 Failed Link for HCD

Appendix A: Test Equipment

Test Group 1: Transmitted FLP Burst Composition

Test #1.28

Test Label: Separation of FLP Bursts

Purpose: To verify proper separation of consecutive FLP bursts.

References:

- ANSI/IEEE Std 802.3u/D5 March 23, 1995 Edition: Sections 28.1.4.1, 28.2.1.1, 28.2.1.1.2

Resource Requirements:

- Line Monitor

Last Modification: July 22, 1996

Discussion: A station capable of auto-negotiation must transmit fast link pulse (FLP) bursts. Not only is the content and composition of these bursts important, but also the timing of the bursts. This test is designed to verify that the timing of the device under test's consecutive FLP bursts fall within the specified range.

Test Setup: Set up the devices as shown. Using Category 5 UTP cable, connect the DUT to a 100 Ω line termination. Connect the Line Monitor's first channel to the DUT's receive pair and second channel to the DUT's transmit pair with differential high impedance taps.

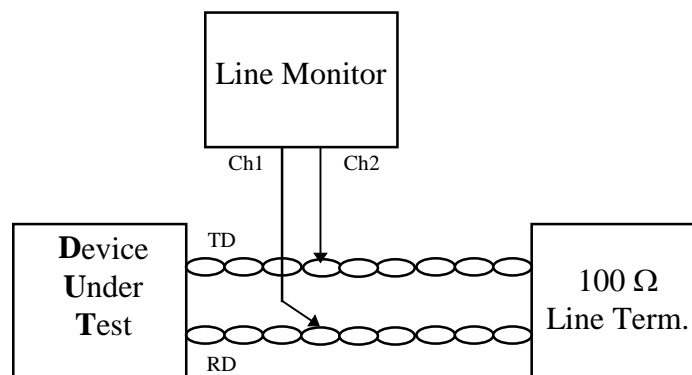

Figure 1.28-1: Test Configuration

Procedure:

1. The DUT is configured to send FLP bursts
2. Monitor the transmitted bursts
3. The separation of each burst is measured

Observable Results:

- The separation of FLP bursts should be 16 ± 8 ms

Test #2.28

Test Label: Internal Separation of FLP Bursts

Purpose: To verify that the device under test transmits FLPs with valid pulse separation.

References:

- ANSI/IEEE Std 802.3u/D5 March 23, 1995 Edition: Sections 28.1.4.1, 28.2.1.1, 28.2.1.1.2

Resource Requirements:

- Line Monitor

Last Modification: July 22, 1996

Discussion: To ensure that the content of an FLP burst is interpreted accurately, the individual pulses that make up the burst must be analyzed. This test is designed to verify that the device under test sends FLP bursts whose clock and data pulses are spaced properly.

Test Setup: See Figure 1.28-1

Procedure:

1. The DUT is configured to send FLP bursts
2. Monitor the transmitted bursts
3. The spacing between clock pulses (starting with the first pulse and then every odd pulse after that) is measured
4. The spacing between clock and data pulses is measured

Observable Results:

- The spacing between clock pulses should be $125 \pm 14 \mu\text{s}$
- The spacing between clock and data pulses should be $62.5 \pm 7 \mu\text{s}$

Test #3.28

Test Label: Number of Pulses in a Burst

Purpose: To verify that the device under test transmits the correct number of pulses in an FLP burst.

References:

- ANSI/IEEE Std 802.3u/D5 March 23, 1995 Edition: Section 28.2.1.1.1

Resource Requirements:

- Line Monitor

Last Modification: July 22, 1996

Discussion: In order for an FLP burst to be considered valid, it must contain a certain number of pulses, namely 17 clock pulses and up to 16 data pulses. This test is designed to verify that the device under test sends FLP bursts with a valid number of pulses.

Test Setup: See Figure 1.28-1

Procedure:

1. The DUT is configured to send FLP bursts
2. Monitor the transmitted bursts
3. The number of pulses present in the burst is measured

Observable Results:

- The number of pulses in a burst should be 17-33 (inclusive)

Test #4.28

Test Label: NLP Compliance

Purpose: To verify the device under test's link pulse waveforms meet specification.

References:

- ANSI/IEEE Std 802.3u/D5 March 23, 1995 Edition: Sections 28.1.4.1, 28.2.1.1, 28.4
- ANSI/IEEE Std 802.3, 1993 Edition: Section 14.3.1.2.1, Figure 14-12

Resource Requirements:

- Oscilloscope
- Differential Voltage Probes
- TP Test Card

Last Modification: July 22, 1996

Discussion: All link pulses need to conform to the transmitter waveform specifications for Link Test Pulses defined in IEEE 802.3 Figure 14-12, including those contained in an FLP burst. This test is designed to verify that the device under test produces link pulses within specification.

Test Setup: Set up the devices as shown. Using Category 5 UTP cable, connect the DUT to the TP Test Card. Connect the Oscilloscope to the TP Test Card using Differential Voltage Probes.

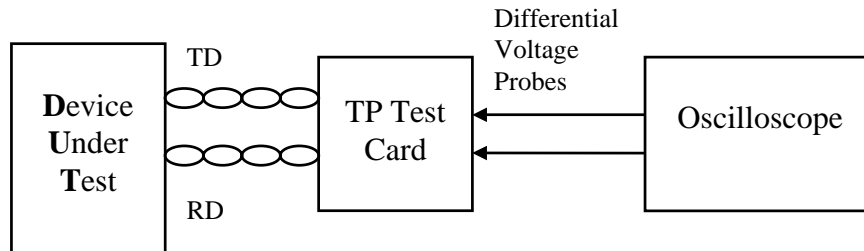

Figure 4.28-1: Test Configuration

Procedure:

1. The DUT is configured to send FLP bursts
2. Monitor the transmitted bursts
3. Observe the link pulse waveforms across each test load defined in fig. 14-11
4. Repeat procedure with loads connected through the TPM

Observable Results:

- Under each test setup, the FLP's link pulses should fit within the NLP template defined in Figure 14-12.
- After the differential output voltage drops below -50 mV, it shall remain below +50 mV.

Test Group 2: Transmitted Link Code Word (Base Page) Encoding

Test #5.28

Test Label: Transmitted Selector Field Combination

Purpose: To verify that the station transmits an acceptable selector field combination.

References:

- ANSI/IEEE Std 802.3u/D5 March 23, 1995 Edition: Sections 28.2.1.2, 28.2.1.2.1, Annex 28A, 28B, 28B.1

Resource Requirements:

- Line Monitor

Last Modification: July 22, 1996

Discussion: There are defined selector field combinations that a station is permitted to transmit in its link code word. This test is designed to verify that the device under test transmits the Selector Field combination corresponding to IEEE 802.3.

Test Setup: See Figure 1.28-1

Procedure:

1. The DUT is configured to send FLP bursts
2. Monitor the transmitted bursts
3. The selector field contents (first five data bits) are acquired

Observable Results:

- The selector field combination should correspond to S[4:0]=00001 as defined in table 28-9

Test #6.28

Test Label: Transmitted Technology Ability Field

Purpose: To verify that the device under test advertises the correct abilities in the technology ability field of the link code word.

References:

- ANSI/IEEE 802.3u/D5 March 23, 1995 Edition: Sections 28.2.1.2, 28.2.1.2.2, Annex 28B.2

Resource Requirements:

- Line Monitor

Last Modification: July 22, 1996

Discussion: The technology ability field of the link code word advertises a station's abilities. This test is designed to verify that the device under test advertises the data service abilities that it supports in its technology ability field.

Test Setup: See Figure 1.28-1

Procedure:

1. The DUT is configured to send FLP bursts
2. Monitor the transmitted bursts
3. The technology ability field contents (D[5:12]) are acquired

Observable Results:

- The technology ability field should advertise the correct abilities when referenced to table 28-10
- The DUT should not advertise any abilities that it does not possess

Test #7.28

Test Label: Remote Fault, Acknowledge, and Next Page Bits

Purpose: To verify that the device under test sends the proper values for the remote fault, acknowledge, and next page bits in the link code word.

References:

- ANSI/IEEE 802.3u/D5 March 23, 1995 Edition: Sections 28.2.1.2, 28.2.1.2.3, 28.2.1.2.4, 28.2.1.2.5

Resource Requirements:

- Line Monitor

Last Modification: July 22, 1996

Discussion: The final three bits in the link code word (remote fault bit, acknowledge bit, next page bit) should all have a proper initial setting. The default value for the RF bit on a non-faulting link is zero. The Ack bit should be initially zero. The NP bit should be one if it supports Next Page exchange and zero if it doesn't or does not wish to implement a NP exchange. This test is designed to verify that the device under test transmits a link code word with these bits set correctly.

Test Setup: See Figure 1.28-1

Procedure:

1. The DUT is configured to send FLP bursts
2. Monitor the transmitted bursts
3. The contents of the remote fault bit, acknowledge bit, and next page bit are acquired

Observable Results:

- The value of the Remote Fault bit should be zero
- The value of the Acknowledge bit should be zero
- The value of the Next Page bit should be one if it supports Next Page exchange and zero if it doesn't or does not wish to implement a NP exchange

Test Group 3: FLP Burst Reception

Test #8.28

Test Label: Acknowledge Bit

Purpose: To verify that the device under test enters the acknowledge detect state upon reception of complete, consecutive and consistent FLP bursts.

References:

- ANSI/IEEE Std 802.3u/D5 March 23, 1995 Edition: Sections 28.2.1.2, 28.1.4.2, 28.2.1.2.4

Resource Requirements:

- Line Monitor
- Traffic Generator

Last Modification: July 23, 1996

Discussion: Once an auto-negotiation identifies its link partner as auto-negotiation able, it will enter the acknowledge detect state only after it receives at least 3 complete, consecutive and consistent link code words from its link partner. Once the acknowledge detect state is entered, the station should send out FLP bursts containing its link code word with the acknowledge bit (the fifteenth data pulse) set to logic one. This test is designed to verify that the device under test will set the acknowledge bit after the reception of 3 or more complete, consecutive and consistent link code words.

Test Setup: Set up the devices as shown. Using Category 5 UTP cable, connect the DUT's transmit pair to a 100 Ω line termination, and the receive pair to a traffic generator. Connect the Line Monitor's first channel to the DUT's receive pair and second channel to the DUT's transmit pair with differential high impedance taps.

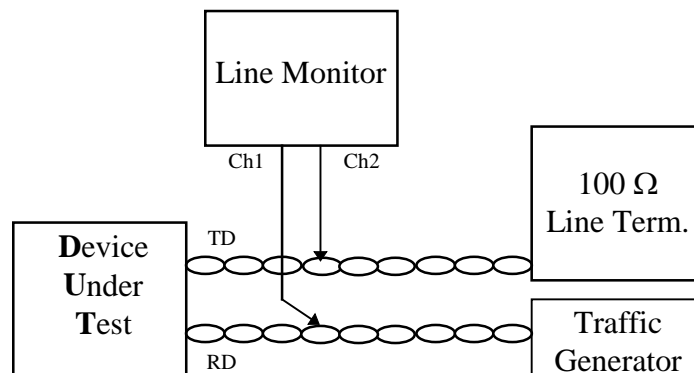

Figure 8.28-1: Test Configuration

Procedure:

Part A:

1. Establish a connection (not a link) to the DUT
2. Use the Traffic Generator to send a series of 3 FLPs

3. Monitor the FLPs sent back by the DUT and determine whether the Acknowledge bit is set
4. If it was not set, repeat the procedure with an increasing number of FLPs until the bit is set

Part B:

1. Establish a connection (not a link) to the DUT
2. Use the Traffic Generator to send enough FLPs, alternating between valid FLPs containing different advertised abilities, such that the number of FLPs would be enough to put the station into the Acknowledge state
3. Monitor the FLPs sent back by the DUT and determine whether the Acknowledge bit is set

Observable Results:

Part A:

- The Acknowledge bit should be set after the reception of at least 3 complete and matching FLPs
- Record the number of FLPs required to put the DUT into the acknowledge state for use in later tests

Part B:

- The DUT should not enter the Acknowledge state

Test #9.28

Test Label: Identification of Link Partner as Auto-Negotiation Able

Purpose: To verify that the device under test is able to recognize its link partner as capable of auto-negotiation within specification.

References:

- ANSI/IEEE Std 802.3u/D5 March 23, 1995 Edition: Section 28.2.2.1

Resource Requirements:

- Traffic Generator

Last Modification: July 22, 1996

Discussion: When establishing a link, a station is required to recognize its link partner as auto-negotiation able within a certain range of pulses in an FLP burst. This test is designed to verify that the device under test adheres to this range.

Test Setup: The setup for this test needs to be one such that the value of the MII Extended Register 6 bit 0 can be determined.

Procedure:

1. Establish a connection (not a link) to the DUT
2. Use a Traffic Generator to send the DUT an incomplete FLP burst composed of only 6 pulses
3. Establish whether the DUT has identified the Link Partner as Auto-Negotiation able
4. If the DUT did not identify the Link Partner as Auto-Negotiation able, repeat the process with a longer FLP until the partner is identified as Auto-Negotiation able

Observable Results:

- The DUT should recognize the Link Partner as auto-negotiation able within 6-17 (inclusive) pulses

Test #10.28

Test Label: Refusal of Incomplete FLPs

Purpose: To verify that the device under test does not accept incomplete FLP bursts.

References:

- ANSI/IEEE Std 802.3u/D5 March 23, 1995 Edition: Sections 28.2.2, 28.2.2.1

Resource Requirements:

- Traffic Generator
- Line Monitor

Last Modification: July 22, 1996

Discussion: A complete FLP burst is composed of 17-33 pulses. This test is designed to verify that a station will not accept an incomplete FLP burst, as specified in the 802.3u standard. Also, the station should not establish a link based solely on carrier sense.

Test Setup: See Figure 8.28-1

Procedure:

Part A:

1. Establish a connection (not a link) to the DUT
2. Verify that the DUT does not establish a link based on carrier sense
3. Use a Traffic Generator to send the DUT enough incomplete FLPs consisting of only 15 pulses to put the DUT into the acknowledge state (see test #8.28)
4. Observe whether the DUT entered the Acknowledge state

Part B:

5. Establish a connection (not a link) to the DUT
6. Use a Traffic Generator to send the DUT a series of the following 2 FLPs alternating at 16 ms apart:
 - a 17 pulse FLP containing the following data: 1 1 0 0 0 1 1 1 1 1 with no clock pulse after the final 1
 - an 8 pulse FLP containing the following data: 0 0 0 0 1 0 with a final clock pulse
7. Observe whether the DUT entered the Acknowledge state

Observable Results:

- The DUT should not enter the Acknowledge state in either case

Test #11.28

Test Label: Acceptance of Long FLPs

Purpose: To verify that the DUT properly accepts FLPs that have more than 33 pulses by ignoring all but the first 16 data bits.

References:

- ANSI/IEEE Std 802.3u/D5 March 23, 1995 Edition: Sections 28.2.2, 28.2.2.1, 28.3.3

Resource Requirements:

- Traffic Generator
- Line Monitor

Last Modification: August 14, 1996

Discussion: An FLP burst normally consists of 17-33 pulses, with normally 16 data bits. However, if a device receives an FLP with more than 33 pulses, it should still accept the burst. The first 16 data bits should be kept and any additional should be ignored. This test is designed to determine whether the Device Under Test properly accepts FLPs with more than 16 data bits.

Test Setup: See Figure 8.28-1

Procedure:

1. Establish a connection (not a link) to the DUT.
2. Use a Traffic Generator to send enough FLPs to put the DUT into the Acknowledge state (see Test #8.28), alternating between valid FLPs and FLPs consisting of the same valid FLP with 5 extra FLPs (3 clock pulses and 2 data pulses) attached to the end.
3. Observe whether the DUT enters the Acknowledge state.

Observable Results:

- The DUT should enter the Acknowledge state

Test #12.28

Test Label: Range of NLP Timer

Purpose: To verify that the device under test accepts FLP bursts with proper spacing, and refuses those with spacing outside of the acceptable range.

References:

- ANSI/IEEE Std 802.3u/D5 March 23, 1995 Edition: Sections 28.2.2.1, 28.3.2

Resource Requirements

- Traffic Generator
- Line Monitor

Last Modification: July 22, 1996

Discussion: As well as characteristic requirements, FLP bursts have requirements for the delay between consecutive bursts. In order to be accepted as valid, received FLP bursts must have a delay between them between “nlp_test_min_timer” and “nlp_test_max_timer.” The value for “nlp_test_min_timer” must be between 5 and 7 ms. The value for “nlp_test_max_timer” must be between 50 and 150 ms. This test is to verify that the device under test accepts FLP bursts with spacing within these ranges, and refuses FLP bursts with spacing outside of these ranges.

Test Setup: See Figure 8.28-1

Procedure:

Part A: Bursts Within Acceptable Range

1. Establish a connection (not a link) to the DUT
2. Use a Traffic Generator to send the DUT enough FLP bursts spaced at 7.1 ms apart to put it into the acknowledge state (see test #8.28)
3. Observe whether the DUT entered the Acknowledge state
4. Repeat using FLPs spaced at 49.9 ms

Part B: Bursts Outside Acceptable Range

5. Repeat using FLPs spaced at 4.9 ms
6. Repeat using FLPs spaced at 150.1 ms

Observable Results:

- In both cases of Part A, the DUT should enter the Acknowledge state
- In both cases of Part B, the DUT should not enter the Acknowledge state

Test #13.28

Test Label: Range of FLP Pulse Timer

Purpose: To verify that the device under test accepts FLPs with pulses spaced within the acceptable range, and refuses those with pulses spaced outside the acceptable range.

References:

- ANSI/IEEE Std 802.3u/D5 March 23, 1995 Edition: Sections 28.2.2.1, 28.3.2

Resource Requirements:

- Line Monitor
- Traffic Generator

Last Modification: July 23, 1996

Discussion: As well as characteristic requirements, FLP bursts have requirements for the delay between consecutive pulses within the burst. In order to be accepted as valid, received pulses must have a delay between them between “flp_test_min_timer” and “flp_test_max_timer.” The value for “flp_test_min_timer” must be between 5 and 25 μs . The value for “flp_test_max_timer” must be between 165 and 185 μs . This test is to verify that the device under test accepts FLP bursts with pulses spaced within these ranges, and refuses FLPs with pulses spaced outside of these ranges.

Test Setup: See Figure 8.28-1

Procedure:

Part A: Pulses Within Acceptable Range

1. Establish a connection (not a link) to the DUT
2. Use a Traffic Generator to send the DUT enough FLPs, alternating between FLPs with pulses spaced at 25.1 μs apart and FLPs with perfect spacing, to put it into the acknowledge state (see test #8.28)
3. Observe whether the DUT entered the Acknowledge state
4. Repeat using FLPs with pulses spaced at 164.9 μs

Part B: Pulses Outside Acceptable Range

5. Repeat using FLPs with pulses spaced at 4.9 μs
6. Repeat using FLPs with pulses spaced at 185.1 μs

Observable Results:

- In both cases of Part A, the DUT should enter the Acknowledge state
- In both cases of Part B, the DUT should not enter the Acknowledge state

Test #14.28

Test Label: Range of Data Detect Timer

Purpose: To verify that the device under test accepts data pulses with proper spacing and refuses data pulses with spacing outside the acceptable range.

References:

- ANSI/IEEE Std 802.3u/D5 March 23, 1995 Edition: Sections 28.2.2.1, 28.3.2

Resource Requirements:

- Line Monitor
- Traffic Generator

Last Modification: July 23, 1996

Discussion: As well as characteristic requirements, FLP bursts have requirements for the delay between clock and data pulses within the burst. In order to be accepted as valid, received data pulses must have a delay between them and the previous clock pulse between “data_detect_min_timer” and “data_detect_max_timer.” The value for “data_detect_min_timer” must be between 15 and 47 μs . The value for “data_detect_max_timer” must be between 78 and 100 μs . This test is to verify that the device under test accepts FLP bursts with data pulses spaced within these ranges, and refuses FLPs with data pulses spaced outside of these ranges.

Test Setup: See Figure 8.28-1

Procedure:

Part A: Data Pulses Within Acceptable Range

1. Establish a connection (not a link) to the DUT
2. Use the Traffic Generator to send the DUT enough FLPs, alternating between FLPs with the data pulses spaced 47.1 μs from the clock pulses and FLPs with perfect spacing, to put it into the acknowledge state (see test #8.28)
3. Observe whether the DUT entered the Acknowledge state
4. Repeat using FLPs with the data pulses spaced 77.9 μs from the clock pulses

Part B: Data Pulses Outside Acceptable Range

5. Repeat using FLPs with the data pulses spaced 14.9 μs from the clock pulses
6. Repeat using FLPs with the data pulses spaced 100.1 μs from the clock pulses

Observable Results:

- In both cases of Part A, the DUT should enter the Acknowledge state
- In both cases of Part B, the DUT should not enter the Acknowledge state

Test #15.28

Test Label: Next Page Bit

Purpose: To verify that the device under test can handle the reception of an FLP from a next page capable device.

References:

- ANSI/IEEE Std 802.3u/D5 March 23, 1995 Edition: Sections 28.2.1.2, 28.2.1.2.5, 28.2.3.4

Resource Requirements:

- Line Monitor
- Traffic Generator

Last Modification: July 23, 1996

Discussion: When a station is connected to a next page able device, it will receive an FLP bursts with set next page bits (the final bit of the link code words set to logic one). Regardless of whether the receiving station is next page able or not, it should still accept the link code word as valid. This test is designed to verify that the device under test is capable of receiving a flagged next page bit.

Test Setup: See Figure 8.28-1

Procedure:

1. Establish a connection (not a link) to the DUT
2. Use the Traffic Generator to send enough FLPs with the next page bit set to a logic one to put it into the acknowledge state (see test #8.28)
3. Verify that the DUT enters the Acknowledge state

Observable Results:

- The DUT should enter the Acknowledge state

Test #16.28

Test Label: Technology Ability Field Reserved Bits

Purpose: To verify that the device under test accepts FLPs with the reserved bits of the technology ability field set to logic one.

References:

- ANSI/IEEE Std 802.3u/D5 March 23, 1995 Edition: Sections 28.2.1.2, 28.2.1.2.2, 28.2.3.3, Annex 28B.2

Resource Requirements:

- Line Monitor
- Traffic Generator

Last Modification: July 23, 1996

Discussion: The last three bits of the technology ability field of a link code word are reserved by the IEEE. A station is supposed to transmit these bits as logic zero, but is supposed to be able to receive these bits set to a one without a problem. This test is designed to verify that the device under test will accept a link code word with the last three bits (the reserved bits) of the technology ability field set to logic one.

Test Setup: See Figure 8.28-1

Procedure:

1. Establish a connection (not a link) to the DUT
2. Use the Traffic Generator to send enough FLPs with the fifth, sixth, and seventh bits of the technology ability field set to logic one to put it into the acknowledge state (see test #8.28)
3. Verify that the DUT enters the Acknowledge state

Observable Results:

- The DUT should enter the Acknowledge state

Test #17.28

Test Label: Selector Field Reserved Combinations

Purpose: To verify that the device under test accepts FLPs with the selector field set to a reserved combination.

References:

- ANSI/IEEE Std 802.3u/D5 March 23, 1995 Edition: Sections 28.2.1.2, 28.2.1.2.1, Annex 28A, 28B, 28B.1

Resource Requirements:

- Line Monitor
- Traffic Generator

Last Modification: July 23, 1996

Discussion: There are combinations for the selector field that are reserved by the IEEE. A station never supposed to transmit these combinations, but there are no specifications as to the combinations that can be received. Therefore, as long as complete and consistent link code words are received, a station should accept them as valid regardless of the selector field combination. This test is designed to verify that the device under test will accept a link code word with the selector field set to a reserved combination.

Test Setup: See Figure 8.28-1

Procedure:

1. Establish a connection (not a link) to the DUT
2. Use the Traffic Generator to send enough FLPs with the selector field combination of 0,0,1,1,1 (ordered bit S0 to S4) to put it into the acknowledge state (see test #8.28)
3. Verify that the DUT enters the Acknowledge state

Observable Results:

- The DUT should enter the Acknowledge state

Test Group 4: Establishing a Link

Test #18.28

Test Label: Complete Acknowledge

Purpose: To verify that the device under test sends out a valid number of link code words after the complete acknowledge state has been entered.

References:

- ANSI/IEEE Std 802.3u/D5 March 23, 1995 Edition: Section 28.2.1.2.4

Resource Requirements:

- Line Monitor
- Traffic Generator

Last Modification: July 23, 1996

Discussion: Well into the auto-negotiation process is the complete acknowledge state. A station reaches this state after first entering the acknowledge state (which is done when at least 3 complete, consecutive and consistent FLP bursts are received- see Test #15.28), then receiving 3 complete, consecutive and consistent FLPs with the acknowledge bit set, and finally upon completion of next page exchange, if necessary. Once the complete acknowledge state has been entered, a station should send out 6 to 8 (inclusive) more FLPs containing its link code word. This test is designed to verify that the device under test sends out the 6 to 8 (inclusive) FLPs after entering the complete acknowledge state.

Test Setup: See Figure 8.28-1

Procedure:

1. Establish a connection (not a link) to the DUT
2. Use the Traffic Generator to send a series of FLPs- first some with the Acknowledge bit not set (enough to put the DUT into the Acknowledge state- refer to results of test #8.28) followed by 3 with the Acknowledge bit set to logic one, to put the DUT into the COMPLETE ACKNOWLEDGE state
3. Monitor the transmit line coming from the DUT and count the number of FLPs sent by the DUT after the COMPLETE ACKNOWLEDGE state has been entered

Observable Results:

- After the COMPLETE ACKNOWLEDGE state has been entered, the DUT should send out 6 to 8 (inclusive) FLPs containing its Link Code Word

Test #19.28

Test Label: Parallel Detection of 10Base-T Devices

Purpose: To verify that the device under test can detect that its link partner is a fixed speed 10Base-T device.

References:

- ANSI/IEEE Std 802.3u/D5 March 23, 1995 Edition: Sections 28.2.2.2, 28.2.3.1, 28.4
- ANSI/IEEE Std 802.3, 1993 Edition: Section 14.3.1.2.1

Resource Requirements:

- Line Monitor
- Traffic Generator

Last Modification: July 23, 1996

Discussion: A station capable of auto-negotiation should be capable of detecting a 10Base-T device as its link partner solely on the receipt of 10Base-T normal link pulses (NLPs). This should occur before the detection of FLP bursts. When a 10Base-T device is detected, the station should either enable its 10Base-T PMA and establish a link if supported, or simply not allow a link to be established if not supported. Also, the station should be able to accept worst-case NLPs, that have one of the following characteristics (these are achieved using the setup shown in Figure 17.28-1:

1. As in Figure 14-12 in IEEE 802.3: with a peak amplitude of 585 mV, a pulse width of 0.60 BT, and a maximum undershoot.
2. As in Figure 14-12 in IEEE 802.3: with maximum allowed amplitude and pulse width.

Test Setup: See Figure 8.28-1

Procedure:

1. Establish a connection (not a link) to the DUT
2. Use the Test Station to send the DUT a series of NLPs spaces at 16 ms apart
3. If the DUT has a 10Base-T PMA, verify that it is enabled by determining whether a link is established
4. Send the DUT a packet and see if it is accepted
5. If the DUT has no 10Base-T PMA, verify that no link is established
6. Repeat using each worst case NLP

Observable Results:

- If the DUT supports a 10Base-T PMA, a link should be established in each case. If not, a link should be refused.

Test #20.28

Test Label: Parallel Detection of 100Base-TX Devices

Purpose: To verify that the device under test can properly parallel detect a fixed speed 100Base-TX link partner.

References:

- ANSI/IEEE Std 802.3u/D5 March 23, 1995 Edition: Section 28.2.3.1

Resource Requirements:

- Line Monitor
- Traffic Generator

Last Modification: July 23, 1996

Discussion: A station capable of auto-negotiation should also implement the parallel detection function. This provides for the detection of a 100Base-TX fixed speed device before the detection of FLPs. In this case, a station should either enable its 100Base-TX PMA if supported and establish a link, or otherwise not allow a link to be established. This test is designed to verify that the device under test properly handles the presence of a fixed speed 100Base-TX device as a link partner.

Test Setup: See Figure 8.28-1

Procedure:

1. Establish a connection (not a link) to the DUT
2. Use the Traffic Generator to simulate the presence of a non-auto-negotiating 100Base-TX device
3. If the DUT has a 100Base-TX PMA, verify that it is enabled by determining whether a link is established
4. Send the DUT a packet and see if it is accepted
5. If the DUT has no 100Base-TX PMA, verify that no link is established

Observable Results:

- If the DUT supports a 100Base-TX PMA, a link should be established. If not, a link should be refused.

Test #21.28

Test Label: Parallel Detection of 100Base-T4 Devices

Purpose: To verify that the device under test can properly parallel detect a fixed speed 100Base-T4 link partner.

References:

- ANSI/IEEE Std 802.3u/D5 March 23, 1995 Edition: Section 28.2.3.1

Resource Requirements:

- Line Monitor
- Traffic Generator

Last Modification: July 23, 1996

Discussion: A station capable of auto-negotiation should also implement the parallel detection function. This provides for the detection of a 100Base-T4 fixed speed device before the detection of FLPs. In this case, a station should either enable its 100Base-T4 PMA if supported and establish a link, or otherwise not allow a link to be established. This test is designed to verify that the device under test properly handles the presence of a fixed speed 100Base-T4 device as a link partner.

Test Setup: See Figure 8.28-1

Procedure:

1. Establish a connection (not a link) to the DUT
2. Use the Traffic Generator to simulate the presence of a non-auto-negotiating 100Base-T4 device
3. If the DUT has a 100Base-T4 PMA, verify that it is enabled by determining whether a link is established
4. Send the DUT a packet and see if it is accepted
5. If the DUT has no 100Base-T4 PMA, verify that no link is established

Observable Results:

- If the DUT supports a 100Base-T4 PMA, a link should be established. If not, a link should be refused.

Test #22.28

Test Label: Priority Resolution Function

Purpose: To verify that the device under test properly configures the highest common denominator (HCD) technology for the transmitted technologies in a link code word.

References:

- ANSI/IEEE Std 802.3u/D5 March 23, 1995 Edition: Sections 28.2.3.3, Annex 28B.2, 28B.3

Resource Requirements:

- Line Monitor
- Traffic Generator

Last Modification: July 23, 1996

Discussion: Once a station has received its link partner's link code word and completed the exchange of FLP bursts, the technology at which communication is to be established must be resolved. Through the priority resolution function, the highest common denominator (HCD) technology should be found. This test is designed to verify that the device under test resolves the proper HCD for all possible technology combinations.

Test Setup: See Figure 8.28-1

Procedure:

1. Establish a connection (not a link) to the DUT
2. Use the Traffic Generator to send a series of FLP bursts that advertise a set of abilities
3. Verify that the DUT establishes a link when it can, and refuses a link otherwise
4. Verify that the DUT resolved the highest common technology by sending a packet to the DUT in that format and determining whether it was received
5. Verify that full duplex was resolved whenever possible
6. Repeat this procedure for all possible combinations of the first five bits of the technology ability field

Observable Results:

- In every case, the DUT should resolve the highest priority possible based on the priority resolution function for the technologies advertised

Test #23.28

Test Label: Failed Link for HCD

Purpose: To verify that the device under test starts a renegotiation upon the reception of a link_status=FAIL from the resolved highest common denominator (HCD) technology.

References:

- ANSI/IEEE Std 802.3u/D5 March 23, 1995 Edition: Section 28.2.3.2

Resource Requirements:

- Line Monitor
- Traffic Generator

Last Modification: July 23, 1996

Discussion: Once the highest common denominator (HCD) technology has been determined through the parallel detection function, if a station receives a link_status=FAIL message from that priority, it should cause a renegotiation. This test is designed to verify that the device under test does start a renegotiation upon the receipt of a link_status=FAIL message from the HCD technology.

Test Setup: See Figure 8.28-1

Procedure:

1. Establish a connection (not a link) to the DUT
2. Use the Traffic Generator to send a series of FLP bursts that advertise a set of abilities
3. Verify the DUT resolves the HCD priority and establishes a link
4. Send the DUT a link_status=FAIL for the HCD priority
5. Verify that the DUT starts a renegotiation

Observable Results:

- The DUT should start a renegotiation upon reception of the link_status=FAIL message

Appendix A: Test Equipment

Traffic Generator

An arbitrary waveform generator (AWG) which matches the specifications in IEEE Std 1802.3d-1993 Section 6.3.4.4 with the exception that the sample resolution shall be 4 ns/point

BAL

100 Ω to 50 Ω balun impedance adapter as defined in IEEE Std 1802.3d-1993 Section 6.3.3.3

Oscilloscope

A digitizing signal analyzer which matches the specifications for an oscilloscope as defined in IEEE Std 1802.3d-1993 Section 6.3.4.8

Differential Voltage Probe

Meets specifications defined in IEEE Std 1802.3d-1993 Section 6.3.4.9

TP Test Card

A testing card with an RJ-45 interface containing the following options:

- Cross over at the input
- Cable termination with 100 Ω load, Test Load 1, or Test Load 2 (as defined in IEEE 802.3 Section 14.3.1.2.1 and Figure 14-11)
- Unshielded twisted pair model (as defined in IEEE Std 802.3 Section 14.3.1.2)
- Link test pulse generator

Line Monitor

A device capable of recording and time stamping the pulses that make up transmitted FLPs

Test		Result	Comments
1.28	Transmitted FLP Burst Composition	<i>a</i>	
2.28	Transmitted Link Code Word Encoding	<i>a</i>	
3.28	Number of Pulses in a Burst	<i>a</i>	
4.28	NLP Compliance	<i>a</i>	
5.28	Transmitted Selector Field Combination	<i>a</i>	
6.28	Transmitted Technology Ability Field	<i>a</i>	
7.28	Remote Fault, Acknowledge, and Next Page Bits	<i>a</i>	
8.28	Acknowledge Bit	<i>a</i>	
		<i>b</i>	
9.28	Identification of Link Partner as Auto-Negotiation Able	<i>a</i>	
10.28	Refusal of Incomplete FLPs	<i>a</i>	
11.28	Range of NLP Timer	<i>a</i>	
		<i>b</i>	
		<i>c</i>	
		<i>d</i>	
12.28	Range of FLP Pulse Timer	<i>a</i>	
		<i>b</i>	
		<i>c</i>	
		<i>d</i>	
13.28	Range of Data Detect Timer	<i>a</i>	
		<i>b</i>	
		<i>c</i>	

		<i>d</i>		
14.28	Next Page Bit	<i>a</i>		
15.28	Technology Ability Field Reserved Bits	<i>a</i>		
16.28	Selector Field Reserved Combinations	<i>a</i>		
17.28	Complete Acknowledge	<i>a</i>		
18.28	Parallel Detection of 10Base-T Devices	<i>a</i>		
		<i>b</i>		
		<i>c</i>		
19.28	Parallel Detection of 100Base-TX Devices	<i>a</i>		
20.28	Parallel Detection of 100Base-T4 Devices	<i>a</i>		
21.28	Priority Resolution Function	<i>a</i>		
22.28	Failed Link for HCD	<i>a</i>		