

# BroadR-Reach Physical Coding Sublayer Test Suite

---

Version 2.0



Author & Company	Alexander Seiger, UNH-IOL Dave Estes, UNH-IOL
Title	BroadR-Reach Physical Coding Sublayer Test Suite
Version	2.0
Date	December 12, 2014
Status	Final
Restriction Level	Public

This suite of tests has been developed to help implementers evaluate the functionality of their BroadR-Reach Physical Coding Sublayer (PCS) based products. This test suite covers both PCS Transmit and PCS Receive, including state diagrams, encoding/decoding, and scrambling/descrambling.

---

**Version Control of Document**

Version	Author	Description	Date
0.1	Dave Estes	Initial Draft	06/25/2012
0.2	Dave Estes	<ul style="list-style-type: none"> <li>Added information about Test Stations and the Line Tap</li> <li>Editorial Updates</li> </ul>	07/18/2012
0.3	Dave Estes	<ul style="list-style-type: none"> <li>Added test 3.2.8</li> </ul>	09/17/2012
0.4	Dave Estes	<ul style="list-style-type: none"> <li>Removed test 3.1.7 - Transmit State Diagram</li> <li>Created Group 2 - Transmit State Diagram</li> </ul>	9/30/2012
0.5	Dave Estes	<ul style="list-style-type: none"> <li>Updated references and test cases for v1.1 of the BroadR-Reach Standard</li> <li>Added 3.2.8 part e</li> <li>Removed test 3.3.7 - Receive State Diagram</li> <li>Created Group 4 - Receive State Diagram</li> </ul>	10/9/2012
0.6	Dave Estes	<ul style="list-style-type: none"> <li>Editorial Updates</li> <li>Clarified that tests 3.3.2 and 3.3.7 are Optional</li> <li>Switched to OPEN Alliance Document Template</li> <li>Updated the Group 4 Possible Problems to include MII access</li> </ul>	1/8/2013
0.7	Dave Estes	<ul style="list-style-type: none"> <li>Removed Test 3.3.7</li> <li>Updated references to BroadR-Reach v1.2</li> <li>Editorial updates</li> </ul>	2/19/2013
0.8	Dave Estes	<ul style="list-style-type: none"> <li>Updated tests 3.2.3-3.2.10</li> <li>Added test 3.1.7</li> </ul>	4/29/2013
1.0	Dave Estes	<ul style="list-style-type: none"> <li>Updated test 3.1.7</li> <li>Added test setup diagrams to Appendix 3.A</li> <li>Editorial updates</li> </ul>	5/28/2013
1.1	Dave Estes	<ul style="list-style-type: none"> <li>Added Appendix 3.C for devices without MII Access</li> <li>Added test 3.5.1</li> <li>Updated all references to BroadR-Reach Specification v2.0</li> </ul>	12/1/2013
1.2	Dave Estes Alex Seiger	<ul style="list-style-type: none"> <li>Added test 3.4.4</li> <li>Editorial updates</li> </ul>	3/30/2014 4/16/2014
1.3	Alex Seiger	<ul style="list-style-type: none"> <li>Minor editorial update to test 3.4.3</li> <li>Updated references to BroadR-Reach Specification v3.1</li> <li>Updated wording of repetition procedures</li> </ul>	6/20/2014
1.4	Alex Seiger	<ul style="list-style-type: none"> <li>Update to test procedures 3.4.11 and 3.4.13</li> <li>Updated standard reference to latest release (v3.2)</li> <li>Document Restriction Level changed to Public</li> <li>Editorial Corrections</li> </ul>	9/18/2014
2.0	Alex Seiger	<ul style="list-style-type: none"> <li>Added test 3.3.7 – De-Interleave Ternary Pairs</li> <li>Editorial Corrections</li> <li>Finalized</li> </ul>	12/12/2014

**Restriction level history of Document**

Version	Restriction Level	Description	Date
0.1	OPEN internal only		06/25/2012
0.2	OPEN internal only		07/18/2012
0.3	OPEN internal only		09/17/2012
0.4	OPEN internal only		9/30/2012
0.5	OPEN internal only		10/9/2012
0.6	OPEN internal only		1/8/2013
0.7	OPEN internal only		2/18/2013
0.8	OPEN internal only		4/29/2013
1.0	OPEN internal only		5/28/2013
1.1	OPEN internal only		12/1/2013
1.2	OPEN internal only		3/30/2014
1.3	OPEN internal only		6/24/2014
1.4	Public		9/18/2014
2.0	Public		12/12/2014

This test suite may not be commercialized in any way without express permission of the UNH-IOL.

## Contents

1	ACKNOWLEDGMENTS .....	6
2	INTRODUCTION .....	7
3	Reference Table .....	9
4	Device Under Test (DUT) Requirements .....	10
5	GROUP 1: PCS Transmit .....	11
5.1	Test 3.1.1 – PCS Signaling .....	12
5.2	Test 3.1.2 – PCS Reset .....	14
5.3	Test 3.1.3 – Transmit Proper SSD .....	15
5.4	Test 3.1.4 – Transmit Proper ESD .....	16
5.5	Test 3.1.5 – Transmit ESD with tx_error .....	17
5.6	Test 3.1.6 – Transmission of Stuff Bits .....	18
5.7	Test 3.1.7 – tx_error .....	19
6	GROUP 2: PCS Transmit State Diagram .....	21
6.1	Test 3.2.1 – PCS Transmit State Diagram - SEND IDLE State .....	22
6.2	Test 3.2.2 – PCS Transmit State Diagram - SSD1 VECTOR and SSD2 VECTOR states .....	23
6.3	Test 3.2.3 – PCS Transmit State Diagram - SSD3 VECTOR state .....	24
6.4	Test 3.2.4 – PCS Transmit State Diagram - TRANSMIT DATA state .....	26
6.5	Test 3.2.5 – PCS Transmit State Diagram - ESD1 VECTOR state .....	28
6.6	Test 3.2.6 – PCS Transmit State Diagram - ESD2 VECTOR state .....	29
6.7	Test 3.2.7 – PCS Transmit State Diagram - ESD3 VECTOR state .....	30
6.8	Test 3.2.8 – PCS Transmit State Diagram - ERR ESD1 VECTOR state .....	31
6.9	Test 3.2.9 – PCS Transmit State Diagram - ERR ESD2 VECTOR state .....	32
6.10	Test 3.2.10 – PCS Transmit State Diagram - ERR ESD3 VECTOR state .....	33
7	GROUP 3: PCS Receive .....	34
7.1	Test 3.3.1 – Receive PCS Signaling .....	35
7.2	Test 3.3.2 – Automatic Polarity Detection (Optional) .....	37
7.3	Test 3.3.3 – Receive SSD .....	38
7.4	Test 3.3.4 – Receive ESD .....	39
7.5	Test 3.3.5 – Receive ERR_ESD3 .....	40
7.6	Test 3.3.6 – Reception of Stuff Bits .....	41
7.7	Test 3.3.7 – De-Interleave Ternary Pairs .....	42

8	GROUP 4: PCS Receive State Diagram .....	43
8.1	Test 3.4.1 – Receive State Diagram - IDLE State.....	44
8.2	Test 3.4.2 – Receive State Diagram - CHECK SSD2 State .....	45
8.3	Test 3.4.3 – Receive State Diagram - CHECK SSD3 State .....	46
8.4	Test 3.4.4 – Receive State Diagram - SSD State.....	47
8.5	Test 3.4.5 – Receive State Diagram - BAD SSD State.....	48
8.6	Test 3.4.6 – Receive State Diagram - FIRST SSD State .....	50
8.7	Test 3.4.7 – Receive State Diagram - SECOND SSD State .....	51
8.8	Test 3.4.8 – Receive State Diagram - THIRD SSD State.....	52
8.9	Test 3.4.9 – Receive State Diagram - DATA State.....	53
8.10	Test 3.4.10 – Receive State Diagram - CHECK ESD2 State .....	54
8.11	Test 3.4.11 – Receive State Diagram - CHECK ESD3 State .....	55
8.12	Test 3.4.12 – Receive State Diagram - BAD ESD2 State .....	56
8.13	Test 3.4.13 – Receive State Diagram - BAD END and RX ERROR states .....	57
9	GROUP 5: JAB State Diagram .....	58
9.1	Test 3.5.1 – JAB State Diagram - rcv_max_timer .....	59
10	TEST SUITE APPENDICES.....	61
10.1	Appendix 3.A –Testing Devices Without MII Access.....	62
10.2	Appendix 3.B – Test Stations .....	71
10.3	Appendix 3.C – Line Tap.....	73

## 1 ACKNOWLEDGMENTS

**The University of New Hampshire would like to acknowledge the efforts of the following individuals in the development of this test suite.**

Curtis Donahue	University of New Hampshire
Dave Estes	University of New Hampshire
Matt Kilpeck	University of New Hampshire
Shawn King	University of New Hampshire
Jeff Lapak	University of New Hampshire
Matt Mayer	University of New Hampshire
Alex Seiger	University of New Hampshire

## 2 INTRODUCTION

The University of New Hampshire's InterOperability Laboratory (IOL) is an institution designed to improve the interoperability of standards based products by providing an environment where a product can be tested against other implementations of a standard. This particular suite of tests has been developed to help implementers evaluate the functionality of the PCS sublayer of their BroadR-Reach products.

These tests are designed to determine if a product conforms to specifications defined in OPEN Alliance BroadR-Reach Physical Layer Transceiver Specification For Automotive Applications Standard. Successful completion of all tests contained in this suite does not guarantee that the tested device will operate with other devices. However, combined with satisfactory operation in the IOL's interoperability test bed, these tests provide a reasonable level of confidence that the Device Under Test (DUT) will function properly in many BroadR-Reach automotive environments.

The tests contained in this document are organized in such a manner as to simplify the identification of information related to a test, and to facilitate in the actual testing process. Tests are organized into groups, primarily in order to reduce setup time in the lab environment, however the different groups typically also tend to focus on specific aspects of device functionality. A three-part numbering system is used to organize the tests, where the first number indicates the section of the OPEN Alliance BroadR-Reach Standard on which the test suite is based. The second and third numbers indicate the test's group number and test number within that group, respectively. This format allows for the addition of future tests to the appropriate groups without requiring the renumbering of the subsequent tests.

The test definitions themselves are intended to provide a high-level description of the motivation, resources, procedures, and methodologies pertinent to each test. Specifically, each test description consists of the following sections:

### **Purpose**

The purpose is a brief statement outlining what the test attempts to achieve. The test is written at the functional level.

### **References**

This section specifies source material *external* to the test suite, including specific subsections pertinent to the test definition, or any other references that might be helpful in understanding the test methodology and/or test results. External sources are always referenced by number when mentioned in the test description. Any other references not specified by number are stated with respect to the test suite document itself.

### **Resource Requirements**

The requirements section specifies the test hardware and/or software needed to perform the test. This is generally expressed in terms of minimum requirements, however in some cases specific equipment manufacturer/model information may be provided.

### **Last Modification**

This specifies the date of the last modification to this test.

### **Discussion**

The discussion covers the assumptions made in the design or implementation of the test, as well as known limitations. Other items specific to the test are covered here.

### **Test Setup**

The setup section describes the initial configuration of the test environment. Small changes in the configuration should not be included here, and are generally covered in the test procedure section, below.

### **Test Procedure**

The procedure section of the test description contains the systematic instructions for carrying out the test. It provides a cookbook approach to testing, and may be interspersed with observable results.

### **Observable Results**

This section lists the specific observables that can be examined by the tester in order to verify that the DUT is operating properly. When multiple values for an observable are possible, this section provides a short discussion on how to interpret them. The determination of a pass or fail outcome for a particular test is generally based on the successful (or unsuccessful) detection of a specific observable.

### **Possible Problems**

This section contains a description of known issues with the test procedure, which may affect test results in certain situations. It may also refer the reader to test suite appendices and/or whitepapers that may provide more detail regarding these issues.



### 3 Reference Table

Test Name	IOL Test Number	BroadR-Reach References
<b>Group 1: PCS Transmit</b>		
PCS Signaling	Test 3.1.1	<ul style="list-style-type: none"> <li>Section 3.2.2 – 4B3B conversion</li> <li>Section 3.2.4.1 – Side-stream scrambler polynomial</li> <li>Section 3.2.4.2 – Generation of Syn[2:0] and Scn[2:0]</li> <li>Section 3.2.4.3 – Generation of scrambling bits Sdn[2:0]</li> <li>Section 3.2.4.4 – Generation of ternary symbol (TA<sub>n</sub>, TB<sub>n</sub>)</li> <li>Table 3.1 – Idle symbol mapping in training</li> <li>Table 3.2 – Data symbols when TXMODE=SEND_N</li> <li>Table 3.3 – Idle symbols when TXMODE=SEND_N</li> </ul>
PCS Reset	Test 3.1.2	<ul style="list-style-type: none"> <li>Section 3.1 – PCS Reset</li> </ul>
Transmit Proper SSD	Test 3.1.3	<ul style="list-style-type: none"> <li>Section 3.2.3 – PCS transmit function</li> <li>Section 3.2.4.4 – Generation of ternary symbol (TA<sub>n</sub>, TB<sub>n</sub>)</li> </ul>
Transmit Proper ESD	Test 3.1.4	<ul style="list-style-type: none"> <li>Section 3.2.3 – PCS transmit function</li> <li>Section 3.2.4.4 – Generation of ternary symbol (TA<sub>n</sub>, TB<sub>n</sub>)</li> </ul>
Transmit ESD with tx_error	Test 3.1.5	<ul style="list-style-type: none"> <li>Section 3.2.3 – PCS transmit function</li> <li>Section 3.2.4.4 – Generation of ternary symbol (TA<sub>n</sub>, TB<sub>n</sub>)</li> </ul>
Transmission of Stuff Bits	Test 3.1.6	<ul style="list-style-type: none"> <li>Section 3.2.2.2 – 4B3B conversion for MII data</li> </ul>
tx_error	Test 3.1.7	<ul style="list-style-type: none"> <li>Section 3.2.3 – PCS Transmit Function</li> <li>Figure 3.3: 4B3B MII control signal conversion</li> </ul>
<b>Group 2: PCS Transmit State Diagram</b>		
Transmit State Diagram	Tests 3.2.1-3.2.10	<ul style="list-style-type: none"> <li>Figure 3.4: PCS Transmit State Diagram</li> </ul>
<b>Group 3: PCS Receive</b>		
Receive PCS Signaling	Test 3.3.1	<ul style="list-style-type: none"> <li>Section 3.3 – PCS Receive</li> </ul>
Automatic Polarity Detection	Test 3.3.4	<ul style="list-style-type: none"> <li>Section 3.3.4 – PCS Receive Automatic Polarity Detection</li> </ul>
Receive SSD	Test 3.3.3	<ul style="list-style-type: none"> <li>Figure 3.8: PCS Receive State Diagram</li> <li>Section 3.3.2 – PCS Receive symbol decoding</li> </ul>
Receive ESD	Test 3.3.4	<ul style="list-style-type: none"> <li>Figure 3.8: PCS Receive State Diagram</li> <li>Section 3.3.2 – PCS Receive symbol decoding</li> </ul>
Receive ERR_ESD3	Test 3.3.5	<ul style="list-style-type: none"> <li>Figure 3.8: PCS Receive State Diagram</li> <li>Section 3.3.2 – PCS Receive symbol decoding</li> </ul>
Reception of Stuff Bits	Test 3.3.6	<ul style="list-style-type: none"> <li>Section 3.3.2 – PCS Receive symbol decoding</li> </ul>
<b>Group 4: PCS Receive State Diagram</b>		
Receive State Diagram	Tests 3.4.1-3.4.13	<ul style="list-style-type: none"> <li>Figure 3.8: PCS Receive State Diagram</li> </ul>
<b>Group 5: JAB State Diagram</b>		
JAB State Diagram - rcv_max_timer	Test 3.5.1	<ul style="list-style-type: none"> <li>Figure 3.8: PCS Receive State Diagram</li> <li>Figure 3.8: JAB State Diagram</li> <li>Section 3.3.1.1 – Variables</li> </ul>

All tests are designed for the OPEN Alliance BroadR-Reach Physical Layer Transceiver Specification For Automotive Applications Standard v3.2

## 4 Device Under Test (DUT) Requirements

For the purposes of this test suite, a DUT is one port of a BroadR-Reach capable device that includes a BroadR-Reach PHY mounted on a PCB and an MDI connector. Please see the additional requirements listed in the following table:

Test Number and Name	Required Capabilities
General	The Ability to send and receive frames <sup>1</sup>
Test 3.1.2 – PCS Reset	Access to PCS Reset
Test 3.1.5 – Transmit ESD with tx_error	MII Access
Test 3.1.7 – tx_error	MII Access
GROUP 2: PCS Transmit State Diagram	MII Access
Test 3.3.2 – Automatic Polarity Detection (Optional)	The DUT must implement Automatic Polarity Detection
GROUP 4: PCS Receive State Diagram	MII Access
GROUP 5: JAB State Diagram	MII Access

1) This can be accomplished through a loopback, responding to ICMP requests, or by forwarding traffic through two ports.

## 5 GROUP 1: PCS Transmit

### Overview:

The tests defined in this section verify the PCS Transmit process defined for BroadR-Reach capable PHYs in sections 3.1 and 3.2 of the OPEN Alliance BroadR-Reach Physical Layer Transceiver Specification For Automotive Applications Standard v3.2.

## 5.1 Test 3.1.1 – PCS Signaling

**Purpose:** To verify that the PCS properly performs the 4B/3B conversion, side-stream scrambling, and ternary symbol generation.

### References:

- [1] OPEN Alliance BroadR-Reach Physical Layer Transceiver Specification For Automotive Applications Standard v3.2, section 3.2.2 – 4B3B conversion
- [2] Ibid., section 3.2.4.1 – Side-stream scrambler polynomial
- [3] Ibid., section 3.2.4.2 – Generation of Syn[2:0]
- [4] Ibid., section 3.2.4.3 – Generation of Scn[2:0]
- [5] Ibid., section 3.2.4.4 – Generation of scrambling bits Sdn[2:0]
- [6] Ibid., section 3.2.4.5 – Generation of ternary pair (TA<sub>n</sub>, TB<sub>n</sub>)
- [7] Ibid., Table 3-6– Idle symbol mapping in training
- [8] Ibid., Table 3-7 – Data symbols when TXMODE=SEND\_N
- [9] Ibid., Table 3-8 – Idle symbols when TXMODE=SEND\_N

### Resource Requirements:

- A test station capable of capturing and decoding ternary symbols
- A compliant BroadR-Reach Link Partner
- A line tap (Refer to appendix 3.C)

**Last Modification:** June 25, 2014 (version 1.3)

### Discussion:

The BroadR-Reach PCS uses a combination of a 4B3B conversion for MII data, side-stream scrambling, and ternary symbols to encode the data for transmission on the line. In addition to the scrambler, there are additional functions performed on the data and idle streams to eliminate the correlation transmit data and to balance the power density.

This test is designed to ensure that the DUT properly performs the BroadR-Reach encoding during training, idle transmission, and data transmission.

**Test Setup:** Connect the Device Under Test (DUT) to the Link Partner via the line tap.

### Test Procedure:

1. Configure the DUT as master and the Link Partner as slave.
2. Monitor and decode the transmissions from the DUT while the DUT is in TXMODE = SEND\_I.
3. Monitor and decode the transmissions from the DUT while the DUT is in TXMODE = SEND\_N and tx\_enable = 1.
4. Monitor and decode the transmissions from the DUT while the DUT is in TXMODE = SEND\_N and tx\_enable = 0.
5. Configure the DUT as slave and the Link Partner as master.
6. Monitor and decode the transmissions from the DUT while the DUT is in TXMODE = SEND\_I.
7. Monitor and decode the transmissions from the DUT while the DUT is in TXMODE = SEND\_N and tx\_enable = 1.
8. Monitor and decode the transmissions from the DUT while the DUT is in TXMODE = SEND\_N and tx\_enable = 0.

### Observable Results:

- a. The transmissions in Step 2 should follow the 4B3B conversion specified in [1], the side-stream scrambler polynomial specified in [2] for master, the generation of Sdn[2:0] specified in [4], and the ternary symbol mapping defined in [6].
- b. The transmissions in Step 3 should follow the 4B3B conversion specified in [1], the side-stream scrambler polynomial specified in [2] for master, the generation of Sdn[2:0] specified in [4], and the ternary symbol mapping defined in [7].
- c. The transmissions in Step 4 should follow the 4B3B conversion specified in [1], the side-stream scrambler polynomial specified in [2] for master, the generation of Sdn[2:0] specified in [4], and the ternary symbol mapping defined in [8].
- d. The transmissions in Step 6 should follow the 4B3B conversion specified in [1], the side-stream scrambler polynomial specified in [2] for master, the generation of Sdn[2:0] specified in [4], and the ternary symbol mapping defined in [6].
- e. The transmissions in Step 7 should follow the 4B3B conversion specified in [1], the side-stream scrambler polynomial specified in [2] for master, the generation of Sdn[2:0] specified in [4], and the ternary symbol mapping defined in [7].
- f. The transmissions in Step 8 should follow the 4B3B conversion specified in [1], the side-stream scrambler polynomial specified in [2] for master, the generation of Sdn[2:0] specified in [4], and the ternary symbol mapping defined in [8].

**Possible Problems:** Some devices may not allow configuration as master or slave, in which case only the supported configuration will be tested.

## 5.2 Test 3.1.2 – PCS Reset

**Purpose:** To verify that the PCS properly initializes upon receipt of a reset request from the management entity.

**References:**

- [1] OPEN Alliance BroadR-Reach Physical Layer Transceiver Specification For Automotive Applications Standard v3.2, section 3.1 – PCS Reset

**Resource Requirements:**

- A test station capable of capturing and decoding ternary symbols
- A compliant BroadR-Reach Link Partner
- A line tap (Refer to appendix 3.C)

**Last Modification:** June 25, 2014 (version 1.3)

**Discussion:**

Reference [1] states that the PCS is reset upon power on or the receipt of a reset request from management entity. The PCS Reset function causes the PCS Transmit State Diagram to transition to the SEND\_IDLE state and the side-stream scrambler to be reset. The initial value of the scrambler shall never be all zeros.

**Test Setup:** Connect the Device Under Test (DUT) to the Link Partner via the line tap.

**Procedure:**

1. Configure the DUT as master.
2. Monitor and decode the transmissions from the DUT and cause the management to request a PCS Reset.
3. Configure the DUT as slave and repeat step 2.

**Observable Results:**

- a. The DUT should transition to the SEND\_IDLE state upon reception of a PCS Reset request when configured as master.
- b. The DUT should transition to the SEND\_IDLE state upon reception of a PCS Reset request when configured as slave.
- c. The DUT should reset the scrambler to a non-zero value upon reception of a PCS Reset request when configured as master.
- d. The DUT should reset the scrambler to a non-zero value upon reception of a PCS Reset request when configured as slave.

**Possible Problems:** If the ability to control the PCS Reset request is not available, this test cannot be performed. Also, some devices may not allow configuration as master or slave, in which case only the supported configuration will be tested.

### 5.3 Test 3.1.3 – Transmit Proper SSD

**Purpose:** To verify that the PCS properly transmits the SSD upon assertion of tx\_enable.

**References:**

- [1] OPEN Alliance BroadR-Reach Physical Layer Transceiver Specification For Automotive Applications Standard v3.2, section 3.2.3 – PCS transmit function
- [2] Ibid., section 3.2.4.5 – Generation of ternary symbol ( $TA_n$ ,  $TB_n$ )

**Resource Requirements:**

- A test station capable of capturing and decoding ternary symbols
- A compliant BroadR-Reach Link Partner
- A line tap (Refer to appendix 3.C)

**Last Modification:** June 25, 2014 (version 1.3)

**Discussion:**

Reference [1] states that the PCS transmits 6 consecutive systems of SSD to the PMA upon assertion of tx\_enable. Reference [2] states that this translates to ternary symbols of (0,0), (0,0), (0,0).

**Test Setup:** Connect the Device Under Test (DUT) to the Link Partner via the line tap.

**Procedure:**

1. Monitor and decode the transmissions from the DUT as the DUT is sending frames.

**Observable Results:**

- a. The DUT should transmit (0,0), (0,0), (0,0) at the beginning of every frame.

**Possible Problems:** None.

## 5.4 Test 3.1.4 – Transmit Proper ESD

**Purpose:** To verify that the PCS properly transmits the ESD upon de-assertion of tx\_enable in the absence of a transmit error.

**References:**

- [1] OPEN Alliance BroadR-Reach Physical Layer Transceiver Specification For Automotive Applications Standard v3.2, section 3.2.3 – PCS transmit function
- [2] Ibid., section 3.2.4.5 – Generation of ternary symbol ( $TA_n$ ,  $TB_n$ )

**Resource Requirements:**

- A test station capable of capturing and decoding ternary symbols
- A compliant BroadR-Reach Link Partner
- A line tap (Refer to appendix 3.C)

**Last Modification:** June 25, 2014 (version 1.3)

**Discussion:**

Reference [1] states that the PCS transmits 6 consecutive systems of ESD to the PMA upon de-assertion of tx\_enable in the absence of transmit errors. Reference [2] states that this translates to ternary symbols of (0,0), (0,0), (1,1).

**Test Setup:** Connect the Device Under Test (DUT) to the Link Partner via the line tap.

**Procedure:**

1. Monitor and decode the transmissions from the DUT as the DUT is sending frames.

**Observable Results:**

- a. The DUT should transmit (0,0), (0,0), (1,1) at the end of every frame that does not have transmit errors.

**Possible Problems:** None.



## 5.5 Test 3.1.5 – Transmit ESD with tx\_error

**Purpose:** To verify that the PCS properly transmits the ESD\_err upon de-assertion of tx\_enable in the presence of a transmit error.

**References:**

- [1] OPEN Alliance BroadR-Reach Physical Layer Transceiver Specification For Automotive Applications Standard v3.2, section 3.2.3 – PCS transmit function
- [2] Ibid., section 3.2.4.5 – Generation of ternary symbol ( $TA_n$ ,  $TB_n$ )

**Resource Requirements:**

- A test station capable of capturing and decoding ternary symbols
- A compliant BroadR-Reach Link Partner
- A line tap (Refer to appendix 3.C)

**Last Modification:** June 25, 2014 (version 1.3)

**Discussion:**

Reference [1] states that the PCS transmits 6 consecutive systems of ESD\_err to the PMA upon de-assertion of tx\_enable in the presence of transmit errors. Reference [2] states that this translates to ternary symbols of (0,0), (0,0), (-1,-1).

**Test Setup:** Connect the Device Under Test (DUT) to the Link Partner via the line tap.

**Procedure:**

1. Monitor and decode the transmissions from the DUT as the DUT is sending frames while causing the DUT to send transmit errors.

**Observable Results:**

- a. The DUT should transmit (0,0), (0,0), (-1,-1) at the end of every frame that has a transmit error.

**Possible Problems:** It will not be possible to perform this test if there is no method to force the DUT to transmit a frame with a transmit error. This can be accomplished through an MII test station if there is direct access to the MII.

## 5.6 Test 3.1.6 – Transmission of Stuff Bits

**Purpose:** To verify that the PCS inserts stuff bits during the 4B3B conversion for MII data.

**References:**

- [1] OPEN Alliance BroadR-Reach Physical Layer Transceiver Specification For Automotive Applications Standard v3.2, section 3.2.2.2 – 4B3B conversion for MII data

**Resource Requirements:**

- A test station capable of capturing and decoding ternary symbols
- A compliant BroadR-Reach Link Partner
- A line tap (Refer to appendix 3.C)

**Last Modification:** June 25, 2014 (version 1.3)

**Discussion:**

Reference [1] states that the DUT shall append stuff bits at the end of every packet that is not a multiple of 3 bits in length.

**Test Setup:** Connect the Device Under Test (DUT) to the Link Partner via the line tap.

**Procedure:**

1. Monitor and decode the transmissions from the DUT as the DUT is sending frames of several lengths that are a multiple of 3 (when including 8 bytes for preamble), including but not limited to 64 bytes and 67 bytes.
2. Monitor and decode the transmissions from the DUT as the DUT is sending frames of several lengths that are 1 more than a multiple of 3 (when including 8 bytes for preamble), including but not limited to 66 bytes and 69 bytes.
3. Monitor and decode the transmissions from the DUT as the DUT is sending frames of several lengths that are 2 more than a multiple of 3 (when including 8 bytes for preamble), including but not limited to 65 bytes and 68 bytes.

**Observable Results:**

- a. In step 1 the DUT should not transmit stuff bits.
- b. In step 2 the DUT should transmit 2 stuff bits.
- c. In step 3 the DUT should transmit 1 stuff bit.

**Possible Problems:** None.

## 5.7 Test 3.1.7 – tx\_error

**Purpose:** To verify that the PCS properly sets tx\_error based on the value of tx\_error\_mii and tx\_enable\_mii.

**References:**

- [1] OPEN Alliance BroadR-Reach Physical Layer Transceiver Specification For Automotive Applications Standard v3.2, section 3.2.3 – PCS Transmit Function
- [2] Ibid., Figure 3-3: 4B3B MII Control Signal Conversion

**Resource Requirements:**

- A test station capable of capturing and decoding ternary symbols
- A test station capable of controlling the MII signals
- A compliant BroadR-Reach Link Partner
- A line tap (Refer to appendix 3.C)

**Last Modification:** June 25, 2014 (version 1.3)

**Discussion:**

Reference [1] states that the DUT shall set tx\_error=TRUE if tx\_error\_mii is asserted during the packet period. References [1] and [2] indicate that tx\_error=TRUE is held until the DUT enters the ERR ESD1 VECTOR state.

**Test Setup:** Connect the Device Under Test (DUT) to the Link Partner via the line tap.

**Procedure:**

1. Configure the test station and Link Partner such that the DUT establishes a valid link while the MII station is sending TXD=0000, TX\_EN=FALSE, and TX\_ER=FALSE.
2. Instruct the MII station to set TXD=0101, TX\_EN=TRUE, and TX\_ER=TRUE for 1 clock cycle, then set TXD=0101, TX\_EN=TRUE, and TX\_ER=FALSE for 5 clock cycles, and then set TXD=0000, TX\_EN=FALSE, and TX\_ER=FALSE for at least 2 clock cycles.
3. Monitor the transmissions from the DUT.
4. Repeat steps 1-3, except instruct the MII station to set TXD=0101, TX\_EN=TRUE, and TX\_ER=FALSE for 7 clock cycles, then set TXD=0000, TX\_EN=TRUE, and TX\_ER=TRUE for 1 clock cycle, and then set TXD=0000, TX\_EN=FALSE, and TX\_ER=FALSE for at least 3 clock cycles in step 2.
5. Repeat steps 1-3, except instruct the MII station to set TXD=0101, TX\_EN=TRUE, and TX\_ER=FALSE for 6 clock cycles, then set TXD=0000, TX\_EN=FALSE, and TX\_ER=TRUE for at least 2 clock cycles in step 2.
6. Repeat steps 1-3, except instruct the MII station to set TXD=0000, TX\_EN=FALSE, and TX\_ER=TRUE for 1 clock cycle, then set TXD=0101, TX\_EN=TRUE, and TX\_ER=FALSE for 6 clock cycles, and then set TXD=0000, TX\_EN=FALSE, and TX\_ER=FALSE for at least 2 clock cycles in step 2.

**Observable Results:**

- a. In step 2, after exiting the TRANSMIT DATA state, the DUT should transmit ESD1, ESD2, and ERR\_ESD3.
- b. In step 4, after exiting the TRANSMIT DATA state, the DUT should transmit ESD1, ESD2, and ERR\_ESD3.

OPEN Alliance

- c. In step 5, after exiting the TRANSMIT DATA state, the DUT should transmit ESD1, ESD2, and ESD3.
- d. In step 6, after exiting the TRANSMIT DATA state, the DUT should transmit ESD1, ESD2, and ESD3

**Possible Problems:** None.

## 6 GROUP 2: PCS Transmit State Diagram

### Overview:

The tests defined in this section verify the PCS Transmit State Diagram defined for BroadR-Reach capable PHYs in section 3.2 of the OPEN Alliance BroadR-Reach Physical Layer Transceiver Specification For Automotive Applications Standard v3.2.

## 6.1 Test 3.2.1 – PCS Transmit State Diagram - SEND IDLE State

**Purpose:** To verify that the DUT properly behaves while in the SEND IDLE state.

**References:**

- [1] OPEN Alliance BroadR-Reach Physical Layer Transceiver Specification For Automotive Applications Standard v3.2, Figure 3-4 – PCS Transmit State Diagram

**Resource Requirements:**

- A test station capable of capturing and decoding ternary symbols
- A test station capable of controlling the MII signals
- A compliant BroadR-Reach Link Partner
- A line tap (Refer to appendix 3.C)

**Last Modification:** June 25, 2014 (version 1.3)

**Discussion:**

Reference [1] shows the valid transitions that a BroadR-Reach device can take through the PCS Transmit State Diagram. The DUT should remain in the SEND IDLE state until tx\_enable=TRUE.

**Test Setup:** Connect the MII of the Device Under Test (DUT) to the MII test station and the BroadR-Reach interface of the DUT to the Link Partner via the line tap.

**Procedure:**

1. Configure the test station and Link Partner such that the DUT establishes a valid link while the MII station is sending TXD=0, TX\_EN=FALSE, and TX\_ER=FALSE.
2. Instruct the MII station to send frame data on TXD while keeping TX\_EN=FALSE.
3. Monitor the transmissions from the DUT.
4. Repeat steps 1-3, except instruct the MII station to set TX\_ER=TRUE in step 2.
5. Repeat steps 1-3, except instruct the MII station to set TX\_ER=FALSE and TX\_EN=TRUE in step 2.
6. Repeat steps 1-3, except instruct the MII station to set TX\_ER=TRUE and TX\_EN=TRUE in step 2.

**Observable Results:**

- a. In step 2, the DUT should remain in the SEND IDLE state.
- b. In step 4, the DUT should remain in the SEND IDLE state.
- c. In step 5, the DUT should transition to the SSD1 VECTOR state and transmit SSD1.
- d. In step 6, the DUT should transition to the SSD1 VECTOR state and transmit SSD1.

**Possible Problems:** This test cannot be performed if direct access to the DUT MII signals is not available.

## 6.2 Test 3.2.2 – PCS Transmit State Diagram - SSD1 VECTOR and SSD2 VECTOR states

**Purpose:** To verify that the DUT properly behaves while in the SSD1 VECTOR and SSD2 VECTOR states.

**References:**

- [1] OPEN Alliance BroadR-Reach Physical Layer Transceiver Specification For Automotive Applications Standard v3.2, Figure 3-4 – PCS Transmit State Diagram

**Resource Requirements:**

- A test station capable of capturing and decoding ternary symbols
- A test station capable of controlling the MII signals
- A compliant BroadR-Reach Link Partner
- A line tap (Refer to appendix 3.C)

**Last Modification:** June 25, 2014 (version 1.3)

**Discussion:**

Reference [1] shows the valid transitions that a BroadR-Reach device can take through the PCS Transmit State Diagram. Regardless of the transmissions on the MII, once the DUT enters the SSD1 VECTOR state the DUT should transmit SSD1, immediately transition to the SSD2 VECTOR state, transmit SSD2, and then immediately transition to the SSD3 VECTOR state.

**Test Setup:** Connect the MII of the Device Under Test (DUT) to the MII test station and the BroadR-Reach interface of the DUT to the Link Partner via the line tap.

**Procedure:**

1. Configure the test station and Link Partner such that the DUT establishes a valid link while the MII station is sending TXD=0000, TX\_EN=FALSE, and TX\_ER=FALSE.
2. Instruct the MII station to set TX\_EN=TRUE and TX\_ER=FALSE for at least 3 clock cycles.
3. Monitor the transmissions from the DUT.
4. Repeat steps 1-3, except instruct the MII station to set TX\_EN=TRUE and TX\_ER=TRUE for at least 3 clock cycles in step 2.
5. Repeat steps 1-3, except instruct the MII station to set TX\_EN=TRUE and TX\_ER=FALSE for 1 clock cycle, and then set TX\_EN=TRUE and TX\_ER=TRUE for at least 2 clock cycles in step 2.
6. Repeat steps 1-3, except instruct the MII station to set TX\_EN=TRUE and TX\_ER=FALSE for 1 clock cycle, then set TX\_EN=FALSE and TX\_ER=FALSE in step 2.
7. Repeat steps 1-3, instruct the MII station to set TX\_EN=TRUE and TX\_ER=FALSE for 1 clock cycle, then set TX\_EN=FALSE and TX\_ER=TRUE in step 2.

**Observable Results:**

- a. In step 2, the DUT should transmit SSD1, SSD2, and SSD3.
- b. In step 4, the DUT should transmit SSD1, SSD2, and SSD3.
- c. In step 5, the DUT should transmit SSD1, SSD2, and SSD3.
- d. In step 6, the DUT should transmit SSD1, SSD2, and SSD3.
- e. In step 7, the DUT should transmit SSD1, SSD2, and SSD3.

**Possible Problems:** This test cannot be performed if direct access to the DUT MII signals is not available.

### 6.3 Test 3.2.3 – PCS Transmit State Diagram - SSD3 VECTOR state

**Purpose:** To verify that the DUT properly behaves while in the SSD3 VECTOR state.

**References:**

- [1] OPEN Alliance BroadR-Reach Physical Layer Transceiver Specification For Automotive Applications Standard v3.2, Figure 3-4 – PCS Transmit State Diagram

**Resource Requirements:**

- A test station capable of capturing and decoding ternary symbols
- A test station capable of controlling the MII signals
- A compliant BroadR-Reach Link Partner
- A line tap (Refer to appendix 3.C)

**Last Modification:** June 25, 2014 (version 1.3)

**Discussion:**

Reference [1] shows the valid transitions that a BroadR-Reach device can take through the PCS Transmit State Diagram. Once the DUT enters the SSD3 VECTOR state, the DUT should transmit SSD3 and then transition to TRANSMIT DATA, ERR ESD1 VECTOR, or ESD1 VECTOR.

**Test Setup:** Connect the MII of the Device Under Test (DUT) to the MII test station and the BroadR-Reach interface of the DUT to the Link Partner via the line tap.

**Procedure:**

1. Configure the test station and Link Partner such that the DUT establishes a valid link while the MII station is sending TXD=0000, TX\_EN=FALSE, and TX\_ER=FALSE.
2. Instruct the MII station to set TXD=0101, TX\_EN=TRUE, and TX\_ER=FALSE for at least 3 clock cycles.
3. Monitor the transmissions from the DUT.
4. Repeat steps 1-3, except instruct the MII station to set TXD=0000, TX\_EN=TRUE and TX\_ER=FALSE for at least 3 clock cycles in step 2.
5. Repeat steps 1-3, except instruct the MII station to set TXD=0101, TX\_EN=TRUE, and TX\_ER=FALSE for 2 clock cycles, and then set TX\_EN=TRUE and TX\_ER=TRUE for at least 1 clock cycle in step 2.
6. Repeat steps 1-3, except instruct the MII station to set TXD=0101, TX\_EN=TRUE, and TX\_ER=FALSE for 2 clock cycles, then set TX\_EN=FALSE and TX\_ER=FALSE for at least 4 clock cycles in step 2.
7. Repeat steps 1-3, except instruct the MII station to set TXD=0101, TX\_EN=TRUE, and TX\_ER=TRUE for 2 clock cycles, then set TX\_EN=FALSE and TX\_ER=FALSE for at least 4 clock cycles in step 2.

**Observable Results:**

- a. In step 2, the DUT should transmit SSD1 and SSD2, enter the SSD3 VECTOR state and transmit SSD3, and then enter the TRANSMIT DATA state and transmit the scrambled version of "010".
- b. In step 4, the DUT should transmit SSD1 and SSD2, enter the SSD3 VECTOR state and transmit SSD3, and then enter the TRANSMIT DATA state and transmit the scrambled version of "000".



## OPEN Alliance

- c. In step 5, the DUT should transmit SSD1 and SSD2, enter the SSD3 VECTOR state and transmit SSD3, and then enter the TRANSMIT DATA state and transmit the scrambled version of "010".
- d. In step 6, the DUT should transmit SSD1 and SSD2, enter the SSD3 VECTOR state and transmit SSD3, enter the ESD1 VECTOR state and transmit ESD1, and then transmit ESD2 and ESD3.
- e. In step 7, the DUT should transmit SSD1 and SSD2, enter the SSD3 VECTOR state and transmit SSD3, enter the ERR ESD1 VECTOR state and transmit ESD1, and then transmit ESD2 and ERR\_ESD3.

**Possible Problems:** This test cannot be performed if direct access to the DUT MII signals is not available.

## 6.4 Test 3.2.4 – PCS Transmit State Diagram - TRANSMIT DATA state

**Purpose:** To verify that the DUT properly behaves while in the TRANSMIT DATA state.

**References:**

- [1] OPEN Alliance BroadR-Reach Physical Layer Transceiver Specification For Automotive Applications Standard v3.2, Figure 3-4 – PCS Transmit State Diagram

**Resource Requirements:**

- A test station capable of capturing and decoding ternary symbols
- A test station capable of controlling the MII signals
- A compliant BroadR-Reach Link Partner
- A line tap (Refer to appendix 3.C)

**Last Modification:** June 25, 2014 (version 1.3)

**Discussion:**

Reference [1] shows the valid transitions that a BroadR-Reach device can take through the PCS Transmit State Diagram. Once the DUT enters the TRANSMIT DATA state, it should remain in this state and encode tx\_data until TX\_EN=FALSE.

**Test Setup:** Connect the MII of the Device Under Test (DUT) to the MII test station and the BroadR-Reach interface of the DUT to the Link Partner via the line tap.

**Procedure:**

1. Configure the test station and Link Partner such that the DUT establishes a valid link while the MII station is sending TXD=0000, TX\_EN=FALSE, and TX\_ER=FALSE.
2. Instruct the MII station to set TXD=0101, TX\_EN=TRUE, and TX\_ER=FALSE for at least 4 clock cycles.
3. Monitor the transmissions from the DUT.
4. Repeat steps 1-3, except instruct the MII station to set TXD=0000, TX\_EN=TRUE and TX\_ER=FALSE for at least 4 clock cycles in step 2.
5. Repeat steps 1-3, except instruct the MII station to set TXD=0101, TX\_EN=TRUE, and TX\_ER=TRUE for at least 4 clock cycles in step 2.
6. Repeat steps 1-3, except instruct the MII station to set TXD=0101, TX\_EN=TRUE, and TX\_ER=FALSE for 4 clock cycles, then set TX\_EN=FALSE and TX\_ER=FALSE for at least 3 clock cycles in step 2.
7. Repeat steps 1-3, except instruct the MII station to set TXD=0101, TX\_EN=TRUE, and TX\_ER=TRUE for 4 clock cycles, then set TX\_EN=FALSE and TX\_ER=FALSE for at least 3 clock cycles in step 2.

**Observable Results:**

- a. In step 2, the DUT should transmit SSD1, SSD2, and SSD3, then enter the TRANSMIT DATA state and transmit the scrambled version of "010" and "101".
- b. In step 4, the DUT should transmit SSD1, SSD2, and SSD3, then enter the TRANSMIT DATA state and transmit the scrambled version of "000" and "000".
- c. In step 5, the DUT should transmit SSD1, SSD2, and SSD3, then enter the TRANSMIT DATA state and transmit the scrambled version of "010" and "101".

## OPEN Alliance

- d. In step 6, the DUT should transmit SSD1, SSD2, and SSD3, then enter the TRANSMIT DATA state and transmit the scrambled version of "010", "101", "0xx", and then transmit ESD1, ESD2, and ESD3. The transmission of "0xx" represents a data bit of 0 and two stuff bits.
- e. In step 7, the DUT should transmit SSD1, SSD2, and SSD3, then enter the TRANSMIT DATA state and transmit the scrambled version of "010", "101", "0xx", and then transmit ESD1, ESD2, and ERR\_ESD3. The transmission of "0xx" represents a data bit of 0 and two stuff bits.

**Possible Problems:** This test cannot be performed if direct access to the DUT MII signals is not available.

## 6.5 Test 3.2.5 – PCS Transmit State Diagram - ESD1 VECTOR state

**Purpose:** To verify that the DUT properly behaves while in the ESD1 VECTOR state.

**References:**

- [1] OPEN Alliance BroadR-Reach Physical Layer Transceiver Specification For Automotive Applications Standard v3.2, Figure 3-4 – PCS Transmit State Diagram

**Resource Requirements:**

- A test station capable of capturing and decoding ternary symbols
- A test station capable of controlling the MII signals
- A compliant BroadR-Reach Link Partner
- A line tap (Refer to appendix 3.C)

**Last Modification:** June 25, 2014 (version 1.3)

**Discussion:**

Reference [1] shows the valid transitions that a BroadR-Reach device can take through the PCS Transmit State Diagram. Regardless of the transmissions on the MII, once the DUT enters the ESD1 VECTOR state the DUT should transmit ESD1, immediately transition to the ESD2 VECTOR state, and transmit ESD2.

**Test Setup:** Connect the MII of the Device Under Test (DUT) to the MII test station and the BroadR-Reach interface of the DUT to the Link Partner via the line tap.

**Procedure:**

1. Configure the test station and Link Partner such that the DUT establishes a valid link while the MII station is sending TXD=0000, TX\_EN=FALSE, and TX\_ER=FALSE.
2. Instruct the MII station to set TXD=0101, TX\_EN=TRUE, and TX\_ER=FALSE for 6 clock cycles, then set TXD=0000, TX\_EN=FALSE, and TX\_ER=FALSE for at least 2 clock cycles.
3. Monitor the transmissions from the DUT.
4. Repeat steps 1-3, except instruct the MII station to set TXD=0101, TX\_EN=TRUE, and TX\_ER=FALSE for 5 clock cycles, then set TXD=0000, TX\_EN=FALSE, and TX\_ER=FALSE for 1 clock cycle, and then set TX\_EN=TRUE in step 2.

**Observable Results:**

- a. In step 2, after exiting the TRANSMIT DATA state, the DUT should transmit ESD1 followed by ESD2.
- b. In step 4, after exiting the TRANSMIT DATA state, the DUT should transmit ESD1 followed by ESD2.

**Possible Problems:** This test cannot be performed if direct access to the DUT MII signals is not available.

## 6.6 Test 3.2.6 – PCS Transmit State Diagram - ESD2 VECTOR state

**Purpose:** To verify that the DUT properly behaves while in the ESD2 VECTOR state.

**References:**

- [1] OPEN Alliance BroadR-Reach Physical Layer Transceiver Specification For Automotive Applications Standard v3.2, Figure 3.4 – PCS Transmit State Diagram

**Resource Requirements:**

- A test station capable of capturing and decoding ternary symbols
- A test station capable of controlling the MII signals
- A compliant BroadR-Reach Link Partner
- A line tap (Refer to appendix 3.C)

**Last Modification:** June 25, 2014 (version 1.3)

**Discussion:**

Reference [1] shows the valid transitions that a BroadR-Reach device can take through the PCS Transmit State Diagram. Regardless of the transmissions on the MII, once the DUT enters the ESD2 VECTOR state the DUT should transmit ESD2, immediately transition to the ESD3 VECTOR state, and transmit ESD3.

**Test Setup:** Connect the MII of the Device Under Test (DUT) to the MII test station and the BroadR-Reach interface of the DUT to the Link Partner via the line tap.

**Procedure:**

1. Configure the test station and Link Partner such that the DUT establishes a valid link while the MII station is sending TXD=0000, TX\_EN=FALSE, and TX\_ER=FALSE.
2. Instruct the MII station to set TXD=0101, TX\_EN=TRUE, and TX\_ER=FALSE for 5 clock cycles, then set TXD=0000, TX\_EN=FALSE, and TX\_ER=FALSE for at least 2 clock cycles.
3. Monitor the transmissions from the DUT.
4. Repeat steps 1-3, except instruct the MII station to set TXD=0101, TX\_EN=TRUE, and TX\_ER=FALSE for 6 clock cycles, then set TXD=0000, TX\_EN=FALSE, and TX\_ER=FALSE for 1 clock cycle, and then set TX\_EN=TRUE in step 2.

**Observable Results:**

- a. In step 2, after exiting the TRANSMIT DATA state, the DUT should transmit ESD1, ESD2, and ESD3.
- b. In step 4, after exiting the TRANSMIT DATA state, the DUT should transmit ESD1, ESD2, and ESD3.

**Possible Problems:** This test cannot be performed if direct access to the DUT MII signals is not available.

## 6.7 Test 3.2.7 – PCS Transmit State Diagram - ESD3 VECTOR state

**Purpose:** To verify that the DUT properly behaves while in the ESD3 VECTOR state.

**References:**

- [1] OPEN Alliance BroadR-Reach Physical Layer Transceiver Specification For Automotive Applications Standard v3.2, Figure 3.4 – PCS Transmit State Diagram

**Resource Requirements:**

- A test station capable of capturing and decoding ternary symbols
- A test station capable of controlling the MII signals
- A compliant BroadR-Reach Link Partner
- A line tap (Refer to appendix 3.C)

**Last Modification:** June 25, 2014 (version 1.3)

**Discussion:**

Reference [1] shows the valid transitions that a BroadR-Reach device can take through the PCS Transmit State Diagram. Regardless of the transmissions on the MII, once the DUT enters the ESD3 VECTOR state the DUT should transmit ESD3, immediately transition to the SEND IDLE state, and transmit IDLE.

**Test Setup:** Connect the MII of the Device Under Test (DUT) to the MII test station and the BroadR-Reach interface of the DUT to the Link Partner via the line tap.

**Procedure:**

1. Configure the test station and Link Partner such that the DUT establishes a valid link while the MII station is sending TXD=0000, TX\_EN=FALSE, and TX\_ER=FALSE.
2. Instruct the MII station to set TXD=0101, TX\_EN=TRUE, and TX\_ER=FALSE for 8 clock cycles, then set TXD=0000, TX\_EN=FALSE, and TX\_ER=FALSE for at least 3 clock cycles.
3. Monitor the transmissions from the DUT.

**Observable Results:**

- a. In step 2, after exiting the TRANSMIT DATA state, the DUT should transmit ESD1, ESD2, ESD3, and Idle.

**Possible Problems:** This test cannot be performed if direct access to the DUT MII signals is not available.

## 6.8 Test 3.2.8 – PCS Transmit State Diagram - ERR ESD1 VECTOR state

**Purpose:** To verify that the DUT properly behaves while in the ESD1 VECTOR state.

**References:**

- [1] OPEN Alliance BroadR-Reach Physical Layer Transceiver Specification For Automotive Applications Standard v3.2, Figure 3.4 – PCS Transmit State Diagram

**Resource Requirements:**

- A test station capable of capturing and decoding ternary symbols
- A test station capable of controlling the MII signals
- A compliant BroadR-Reach Link Partner
- A line tap (Refer to appendix 3.C)

**Last Modification:** June 25, 2014 (version 1.3)

**Discussion:**

Reference [1] shows the valid transitions that a BroadR-Reach device can take through the PCS Transmit State Diagram. Regardless of the transmissions on the MII, once the DUT enters the ERR ESD1 VECTOR state the DUT should transmit ESD1, immediately transition to the ERR ESD2 VECTOR state, and transmit ESD2.

**Test Setup:** Connect the MII of the Device Under Test (DUT) to the MII test station and the BroadR-Reach interface of the DUT to the Link Partner via the line tap.

**Procedure:**

1. Configure the test station and Link Partner such that the DUT establishes a valid link while the MII station is sending TXD=0000, TX\_EN=FALSE, and TX\_ER=FALSE.
2. Instruct the MII station to set TXD=0101, TX\_EN=TRUE, and TX\_ER=TRUE for 6 clock cycles, then set TXD=0000, TX\_EN=FALSE, and TX\_ER=FALSE for at least 2 clock cycles.
3. Monitor the transmissions from the DUT.
4. Repeat steps 1-3, except instruct the MII station to set TXD=0101, TX\_EN=TRUE, and TX\_ER=TRUE for 5 clock cycles, then set TXD=0000, TX\_EN=FALSE, and TX\_ER=FALSE for 1 clock cycle, and then set TX\_EN=TRUE in step 2.

**Observable Results:**

- a. In step 2, after exiting TRANSMIT DATA state, the DUT should transmit ESD1, ESD2, and ERR\_ESD3.
- b. In step 4, after exiting TRANSMIT DATA state, the DUT should transmit ESD1, ESD2, and ERR\_ESD3.

**Possible Problems:** This test cannot be performed if direct access to the DUT MII signals is not available.

## 6.9 Test 3.2.9 – PCS Transmit State Diagram - ERR ESD2 VECTOR state

**Purpose:** To verify that the DUT properly behaves while in the ERR ESD2 VECTOR state.

**References:**

- [1] OPEN Alliance BroadR-Reach Physical Layer Transceiver Specification For Automotive Applications Standard v3.2, Figure 3.4 – PCS Transmit State Diagram

**Resource Requirements:**

- A test station capable of capturing and decoding ternary symbols
- A test station capable of controlling the MII signals
- A compliant BroadR-Reach Link Partner
- A line tap (Refer to appendix 3.C)

**Last Modification:** June 25, 2014 (version 1.3)

**Discussion:**

Reference [1] shows the valid transitions that a BroadR-Reach device can take through the PCS Transmit State Diagram. Regardless of the transmissions on the MII, once the DUT enters the ERR ESD2 VECTOR state the DUT should transmit ESD2, immediately transition to the ERR ESD3 VECTOR state, and transmit ERR\_ESD3.

**Test Setup:** Connect the MII of the Device Under Test (DUT) to the MII test station and the BroadR-Reach interface of the DUT to the Link Partner via the line tap.

**Procedure:**

1. Configure the test station and Link Partner such that the DUT establishes a valid link while the MII station is sending TXD=0000, TX\_EN=FALSE, and TX\_ER=FALSE.
2. Instruct the MII station to set TXD=0101, TX\_EN=TRUE, and TX\_ER=TRUE for 5 clock cycles, then set TXD=0000, TX\_EN=FALSE, and TX\_ER=FALSE for at least 2 clock cycles.
3. Monitor the transmissions from the DUT.
4. Repeat steps 1-3, except instruct the MII station to set TXD=0101, TX\_EN=TRUE, and TX\_ER=TRUE for 6 clock cycles, then set TXD=0000, TX\_EN=FALSE, and TX\_ER=FALSE for 1 clock cycle, and then set TX\_EN=TRUE in step 2.

**Observable Results:**

- a. In step 2, after exiting the TRANSMIT DATA state, the DUT should transmit ESD1, ESD2, and ERR\_ESD3.
- b. In step 4, after exiting the TRANSMIT DATA state, the DUT should transmit ESD1, ESD2, and ERR\_ESD3.

**Possible Problems:** This test cannot be performed if direct access to the DUT MII signals is not available.



## 6.10 Test 3.2.10 – PCS Transmit State Diagram - ERR ESD3 VECTOR state

**Purpose:** To verify that the DUT properly behaves while in the ERR ESD3 VECTOR state.

**References:**

- [1] OPEN Alliance BroadR-Reach Physical Layer Transceiver Specification For Automotive Applications Standard v3.2, Figure 3.4 – PCS Transmit State Diagram

**Resource Requirements:**

- A test station capable of capturing and decoding ternary symbols
- A test station capable of controlling the MII signals
- A compliant BroadR-Reach Link Partner
- A line tap (Refer to appendix 3.C)

**Last Modification:** June 25, 2014 (version 1.3)

**Discussion:**

Reference [1] shows the valid transitions that a BroadR-Reach device can take through the PCS Transmit State Diagram. Regardless of the transmissions on the MII, once the DUT enters the ERR ESD3 VECTOR state the DUT should transmit ERR\_ESD3, immediately transition to the SEND IDLE state, and transmit IDLE.

**Test Setup:** Connect the MII of the Device Under Test (DUT) to the MII test station and the BroadR-Reach interface of the DUT to the Link Partner via the line tap.

**Procedure:**

1. Configure the test station and Link Partner such that the DUT establishes a valid link while the MII station is sending TXD=0000, TX\_EN=FALSE, and TX\_ER=FALSE.
2. Instruct the MII station to set TXD=0101, TX\_EN=TRUE, and TX\_ER=TRUE for 8 clock cycles, then set TXD=0000, TX\_EN=FALSE, and TX\_ER=FALSE for at least 3 clock cycles.
3. Monitor the transmissions from the DUT.

**Observable Results:**

- a. In step 2, after exiting the TRANSMIT DATA state, the DUT should transmit ESD1, ESD2, ERR\_ESD3, and Idle.

**Possible Problems:** This test cannot be performed if direct access to the DUT MII signals is not available.

## 7 GROUP 3: PCS Receive

### **Overview:**

The tests defined in this section verify the PCS Receive process defined for BroadR-Reach capable PHYs in section 3.3 of the OPEN Alliance BroadR-Reach Physical Layer Transceiver Specification For Automotive Applications Standard v3.2.

## 7.1 Test 3.3.1 – Receive PCS Signaling

**Purpose:** To verify that the PCS properly decodes BroadR-Reach signaling.

**References:**

- [1] OPEN Alliance BroadR-Reach Physical Layer Transceiver Specification For Automotive Applications Standard v3.2, section 3.3 – PCS Receive

**Resource Requirements:**

- A test station capable of capturing and decoding ternary symbols
- A compliant BroadR-Reach Link Partner
- A line tap (Refer to appendix 3.C)

**Last Modification:** June 25, 2014 (version 1.3)

**Discussion:**

The BroadR-Reach PCS uses a combination of a 4B3B conversion for MII data, side-stream scrambling, and ternary symbols to encode the data for transmission on the line. In addition to the scrambler, there are additional functions performed on the data and idle eliminate the correlation transmit data and to balance the power density.

This test is designed to ensure that the DUT properly decodes the BroadR-Reach signaling during training, idle transmission, and data transmission.

**Test Setup:** Connect the Device Under Test (DUT) to the Link Partner via the line tap.

**Test Procedure:**

1. Configure the DUT as MASTER and the Link Partner as SLAVE.
2. Connect the DUT to a Link Partner and configure both devices to perform training and establish a link. Monitor the management indications from the DUT.
3. Connect the DUT to a Link Partner, establish a link, and configure the Link Partner to transmit valid frames to the DUT. Monitor the management indications from the DUT.
4. Connect the DUT to a Link Partner, establish a link, and configure the Link Partner to transmit Idle without frames. Monitor the management indications from the DUT.
5. Configure the DUT as SLAVE and the Link Partner as MASTER.
6. Connect the DUT to a Link Partner and configure both devices to perform training and establish a link. Monitor the management indications from the DUT.
7. Connect the DUT to a Link Partner, establish a link, and configure the Link Partner to transmit valid frames to the DUT. Monitor the management indications from the DUT.
8. Connect the DUT to a Link Partner, establish a link, and configure the Link Partner to transmit Idle without frames. Monitor the management indications from the DUT.

**Observable Results:**

- a. In step 2 The DUT should accept the idle pattern and establish a link.
- b. In step 3 The DUT should indicate link and should receive valid frames.
- c. In step 4 the DUT should indicate reception of idle and maintain the link.
- d. In step 6 The DUT should accept the idle pattern and establish a link.
- e. In step 7 The DUT should indicate link and should receive valid frames.
- f. In step 8 the DUT should indicate reception of idle and maintain the link.

OPEN Alliance

**Possible Problems:** None.

## 7.2 Test 3.3.2 – Automatic Polarity Detection (Optional)

**Purpose:** To verify that the PCS properly detects polarity.

**References:**

- [1] OPEN Alliance BroadR-Reach Physical Layer Transceiver Specification For Automotive Applications Standard v3.2, section 3.3.4 – PCS Receive Automatic Polarity Detection

**Resource Requirements:**

- A test station capable of capturing and decoding ternary symbols
- A compliant BroadR-Reach Link Partner
- A line tap (Refer to appendix 3.C)

**Last Modification:** June 25, 2014 (version 1.3)

**Discussion:**

Reference [1] states that the DUT shall automatically detect the polarity of the received signal.

**Test Setup:** Connect the Device Under Test (DUT) to the Link Partner via the line tap.

**Procedure:**

1. Connect the DUT to the Link Partner, transmit several frames and observe that the link has successfully been established.
2. Switch the polarity by reversing the pair connecting the DUT to the Link Partner. Transmit several frames and observe that the link has successfully been established.

**Observable Results:**

- a. The DUT should establish a link regardless of the receive polarity.

**Possible Problems:** Automatic Polarity Detection is an optional function. This test cannot be completed if the DUT does not implement Automatic Polarity Detection.

### 7.3 Test 3.3.3 – Receive SSD

**Purpose:** To verify that the PCS properly accepts frames with valid SSD.

**References:**

- [1] OPEN Alliance BroadR-Reach Physical Layer Transceiver Specification For Automotive Applications Standard v3.2, Figure 3-7 – PCS Receive state diagram
- [2] Ibid., section 3.3.2 – PCS Receive symbol decoding

**Resource Requirements:**

- A test station capable of capturing and decoding ternary symbols
- A compliant BroadR-Reach Link Partner
- A line tap (Refer to appendix 3.C)

**Last Modification:** June 25, 2014 (version 1.3)

**Discussion:**

The DUT should accept frames with valid SSD of (0,0), (0,0), (0,0).

**Test Setup:** Connect the Device Under Test (DUT) to the Link Partner via the line tap.

**Procedure:**

1. Transmit frames with valid SSD to the DUT while monitoring the DUT transmissions and counters.

**Observable Results:**

- a. The DUT should accept all frames.

**Possible Problems:** None.

## 7.4 Test 3.3.4 – Receive ESD

**Purpose:** To verify that the PCS properly accepts a frame with valid ESD.

**References:**

- [1] OPEN Alliance BroadR-Reach Physical Layer Transceiver Specification For Automotive Applications Standard v3.2, Figure 3-7 – PCS Receive state diagram
- [2] Ibid., section 3.3.2 – PCS Receive symbol decoding

**Resource Requirements:**

- A test station capable of capturing and decoding ternary symbols
- A compliant BroadR-Reach Link Partner
- A line tap (Refer to appendix 3.C)

**Last Modification:** June 25, 2014 (version 1.3)

**Discussion:**

The DUT should accept the frame with valid ESD of (0,0), (0,0), (1,1).

**Test Setup:** Connect the Device Under Test (DUT) to the Link Partner via the line tap.

**Procedure:**

1. Transmit valid frames to the DUT while monitoring the DUT transmissions and counters.

**Observable Results:**

- a. The DUT should accept all frames.

**Possible Problems:** None.

## 7.5 Test 3.3.5 – Receive ERR\_ESD3

**Purpose:** To verify that the PCS properly indicates reception of an error upon reception of ERR\_ESD3.

**References:**

- [1] OPEN Alliance BroadR-Reach Physical Layer Transceiver Specification For Automotive Applications Standard v3.2, Figure 3-7 – PCS Receive state diagram
- [2] Ibid., section 3.3.2 – PCS Receive symbol decoding

**Resource Requirements:**

- A test station capable of capturing and decoding ternary symbols
- A compliant BroadR-Reach Link Partner
- A line tap (Refer to appendix 3.C)

**Last Modification:** June 25, 2014 (version 1.3)

**Discussion:**

Reference [1] shows that the DUT transitions to the RX\_ERROR state and [2] states that the DUT shall set pcs\_rx\_er upon reception of ERR\_ESD3.

**Test Setup:** Connect the Device Under Test (DUT) to the test station via the line tap.

**Procedure:**

1. Transmit a frame with ERR\_ESD3 to the DUT while monitoring the DUT transmissions and counters.

**Observable Results:**

- a. The DUT should indicate reception of an errored frame.

**Possible Problems:** None.



## 7.6 Test 3.3.6 – Reception of Stuff Bits

**Purpose:** To verify that the PCS removes stuff bits during the 3B4B conversion for MII data.

**References:**

- [1] OPEN Alliance BroadR-Reach Physical Layer Transceiver Specification For Automotive Applications Standard v3.2, section 3.3.2 – PCS Receive symbol decoding

**Resource Requirements:**

- A test station capable of capturing and decoding ternary symbols
- A compliant BroadR-Reach Link Partner
- A line tap (Refer to appendix 3.C)

**Last Modification:** June 25, 2014 (version 1.3)

**Discussion:**

Reference [1] states that the DUT shall discard stuff bits that are inserted during the 4B3B transmit process.

**Test Setup:** Connect the Device Under Test (DUT) to the Link Partner via the line tap.

**Procedure:**

1. Transmit frames of several lengths that are a multiple of 3 (when including 8 bytes for preamble), including but not limited to 64 bytes and 67 bytes, to the DUT while monitoring the DUT transmissions and counters.
2. Transmit frames of several lengths that are 1 more than a multiple of 3 (when including 8 bytes for preamble), including but not limited to 66 bytes and 69 bytes, to the DUT while monitoring the DUT transmissions and counters.
3. Transmit frames of several lengths that are 2 more than a multiple of 3 (when including 8 bytes for preamble), including but not limited to 65 bytes and 68 bytes, to the DUT while monitoring the DUT transmissions and counters.

**Observable Results:**

- a. The DUT should accept all frames.

**Possible Problems:** None.

## 7.7 Test 3.3.7 – De-Interleave Ternary Pairs

**Purpose:** To verify that the PCS receiver properly De-Interleaves the received ternary symbols in either ordering.

**References:**

- [1] OPEN Alliance BroadR-Reach Physical Layer Transceiver Specification For Automotive Applications Standard v3.2, section 3.2.4.6 – Generation of symbol sequence

**Resource Requirements:**

- A test station capable of transmitting ternary symbols in either interleave order

**Last Modification:** October 27, 2014 (version 1.5)

**Discussion:**

Reference [1] states that the DUT shall de-interleave the serial stream of ternary symbols as  $(TA_n, TB_n)$  or  $(TB_n, TA_n)$  to match the interleave order of the transmitter.

**Test Setup:** Connect the Device Under Test (DUT) to the Test Station.

**Procedure:**

1. Configure the test station to interleave the serial stream of ternary symbols as  $(TA_n, TB_n)$ .
2. Connect the DUT to the test station, perform training, establish a link, and transmit frames. Monitor the management indications from the DUT.
3. Repeat steps 1-2, but configure the test station to interleave the serial stream of ternary symbols as  $(TB_n, TA_n)$ .

**Observable Results:**

- a. In step 2, the DUT should establish a valid link and receive the transmitted frames.
- b. In step 3, the DUT should establish a valid link and receive the transmitted frames.

**Possible Problems:** None.

## 8 GROUP 4: PCS Receive State Diagram

### Overview:

The tests defined in this section verify the PCS Receive State Diagram defined for BroadR-Reach capable PHYs in section 3.3 of the OPEN Alliance BroadR-Reach Physical Layer Transceiver Specification For Automotive Applications Standard v3.2.

## 8.1 Test 3.4.1 – Receive State Diagram - IDLE State

**Purpose:** To verify that the DUT behaves properly while in the IDLE state.

**References:**

- [1] OPEN Alliance BroadR-Reach Physical Layer Transceiver Specification For Automotive Applications Standard v3.2, Figure 3-7 – PCS Receive State Diagram

**Resource Requirements:**

- A test station capable of transmitting ternary symbols
- A test station capable of capturing the MII signals from the DUT

**Last Modification:** June 25, 2014 (version 1.3)

**Discussion:**

Reference [1] shows the valid transitions that a BroadR-Reach device can take through the PCS Receive State Diagram. The DUT should remain in the IDLE state while it is receiving Idle.

**Test Setup:** Connect the Device Under Test (DUT) to the test stations via the BroadR-Reach and MII interfaces.

**Procedure:**

1. Configure the test stations such that the DUT establishes a valid link while the test station is sending valid Idle.
2. Instruct the test station to send 3 SSD symbols.
3. Monitor the MII transmissions from the DUT.
4. Repeat steps 1-3, except instruct the test station to send a Ternary symbol that does not represent SSD1 or a valid Idle code in step 2.

**Observable Results:**

- a. In step 2, the DUT should set RX\_DV=TRUE and RXD=0101 for two clock cycles, then RXD=xxx1 where x is determined by the test pattern sent from the testing station.
- b. In step 4, the DUT should set RX\_ER=TRUE.

**Possible Problems:** This test cannot be performed if direct access to the DUT MII signals is not available.

## 8.2 Test 3.4.2 – Receive State Diagram - CHECK SSD2 State

**Purpose:** To verify that the DUT behaves properly while in the CHECK SSD2 state.

**References:**

- [1] OPEN Alliance BroadR-Reach Physical Layer Transceiver Specification For Automotive Applications Standard v3.2, Figure 3-7 – PCS Receive State Diagram

**Resource Requirements:**

- A test station capable of transmitting ternary symbols
- A test station capable of capturing the MII signals from the DUT

**Last Modification:** June 25, 2014 (version 1.3)

**Discussion:**

Reference [1] shows the valid transitions that a BroadR-Reach device can take through the PCS Receive State Diagram. Once the DUT is in the CHECK SSD2 state, it should transition to the CHECK SSD3 state if it receives SSD2 or transition to the BAD SSD state if it receives anything else.

**Test Setup:** Connect the Device Under Test (DUT) to the test stations via the BroadR-Reach and MII interfaces.

**Procedure:**

1. Configure the test stations such that the DUT establishes a valid link while the test station is sending valid Idle.
2. Instruct the test station to send 3 SSD symbols.
3. Monitor the MII transmissions from the DUT.
4. Repeat steps 2-3, except instruct the test station to send SSD1 followed by a Ternary symbol other than SSD2 in step 2.

**Observable Results:**

- a. In step 2, the DUT should set RX\_DV=TRUE and RXD=0101 .
- b. In step 4, the DUT should set RX\_ER=TRUE.

**Possible Problems:** This test cannot be performed if direct access to the DUT MII signals is not available.

### 8.3 Test 3.4.3 – Receive State Diagram - CHECK SSD3 State

**Purpose:** To verify that the DUT behaves properly while in the CHECK SSD3 state.

**References:**

- [1] OPEN Alliance BroadR-Reach Physical Layer Transceiver Specification For Automotive Applications Standard v3.2, Figure 3-7 – PCS Receive State Diagram

**Resource Requirements:**

- A test station capable of transmitting ternary symbols
- A test station capable of capturing the MII signals from the DUT

**Last Modification:** June 25, 2014 (version 1.3)

**Discussion:**

Reference [1] shows the valid transitions that a BroadR-Reach device can take through the PCS Receive State Diagram. Once the DUT is in the CHECK SSD3 state, it should transition to the SSD state if it receives SSD3 or transition to the BAD SSD state if it receives anything else.

**Test Setup:** Connect the Device Under Test (DUT) to the test stations via the BroadR-Reach and MII interfaces.

**Procedure:**

1. Configure the test stations such that the DUT establishes a valid link while the test station is sending valid Idle.
2. Instruct the test station to send 3 SSD symbols.
3. Monitor the MII transmissions from the DUT.
4. Repeat steps 2-3, except instruct the test station to send 2 SSD symbols followed by a Ternary symbol other than SSD3 in step 2.

**Observable Results:**

- a. In step 2, the DUT should set RX\_DV=TRUE and RXD=0101.
- b. In step 4, the DUT should set RX\_ER=TRUE.

**Possible Problems:** This test cannot be performed if direct access to the DUT MII signals is not available.

## 8.4 Test 3.4.4 – Receive State Diagram - SSD State

**Purpose:** To verify that the DUT behaves properly while in the SSD state.

**References:**

- [1] OPEN Alliance BroadR-Reach Physical Layer Transceiver Specification For Automotive Applications Standard v3.2, Figure 3-7 – PCS Receive State Diagram

**Resource Requirements:**

- A test station capable of transmitting ternary symbols
- A test station capable of capturing the MII signals from the DUT

**Last Modification:** June 25, 2014 (version 1.3)

**Discussion:**

Reference [1] shows the valid transitions that a BroadR-Reach device can take through the PCS Receive State Diagram. Regardless of what is being received, once the DUT enters the SSD state it should set transition to the FIRST SSD state.

**Test Setup:** Connect the Device Under Test (DUT) to the test stations via the BroadR-Reach and MII interfaces.

**Procedure:**

1. Configure the test stations such that the DUT establishes a valid link while the test station is sending valid Idle.
2. Instruct the test station to send 3 SSD symbols followed by a Ternary symbol for 010.
3. Monitor the MII transmissions from the DUT.
4. Repeat steps 2-3, except instruct the test station to send 3 SSD symbols followed by a Ternary symbol for data 000 in step 3.
5. Repeat steps 2-3, except instruct the test station to send 3 SSD symbols followed by the Ternary symbol for SSD1 in step 3.

**Observable Results:**

- a. In step 2, the DUT should transition to FIRST SSD and set RX\_DV=TRUE and RXD=0101.
- b. In step 4, the DUT should transition to FIRST SSD and set RX\_DV=TRUE and RXD=0101.
- c. In step 5, the DUT should transition to FIRST SSD and set RX\_DV=TRUE and RXD=0101

**Possible Problems:** This test cannot be performed if direct access to the DUT MII signals is not available.

## 8.5 Test 3.4.5 – Receive State Diagram - BAD SSD State

**Purpose:** To verify that the DUT behaves properly while in the BAD SSD state.

**References:**

- [1] OPEN Alliance BroadR-Reach Physical Layer Transceiver Specification For Automotive Applications Standard v3.2, Figure 3-7 – PCS Receive State Diagram
- [2] Ibid., section 3.3.1.1 Variables

**Resource Requirements:**

- A test station capable of transmitting ternary symbols
- A test station capable of capturing the MII signals from the DUT

**Last Modification:** June 25, 2014 (version 1.3)

**Discussion:**

Reference [1] shows the valid transitions that a BroadR-Reach device can take through the PCS Receive State Diagram. The DUT enters the BAD SSD state upon reception of an error in the IDLE, CHECK SSD2, or CHECK SSD3 states. While in BAD SSD the DUT sets RX\_ER=TRUE. The DUT waits for check\_idle=TRUE to transition back to the IDLE state. The DUT should set check\_idle=TRUE upon reception of 6 consecutive valid Idle symbols.

**Test Setup:** Connect the Device Under Test (DUT) to the test stations via the BroadR-Reach and MII interfaces.

**Procedure:**

1. Configure the test stations such that the DUT establishes a valid link while the test station is sending valid Idle.
2. Instruct the test station to send several Ternary symbols that do not represent SSD or valid Idle.
3. Monitor the MII transmissions from the DUT.
4. Repeat steps 2-3, except instruct the test station to send SSD followed by several Ternary symbols that do not represent SSD or valid Idle in step 2.
5. Repeat steps 2-3, except instruct the test station to send 2 SSD symbols followed by several Ternary symbols that do not represent SSD or valid Idle in step 2.
6. Repeat steps 2-3, except instruct the test station to transmit a Ternary symbol that does not represent SSD or valid Idle, followed by 1 Idle symbol and a valid frame in step 2.
7. Repeat step 6, except send additional Idle symbols before the frame until the DUT is observed to accept the frame.
8. Repeat steps 6 and 7, except send an SSD symbol, 1 Ternary symbol that does not represent SSD or valid Idle, 1 Idle symbol, and a valid frame in step 6. Increase the number of Idle symbols until the DUT is observed to accept the frame in step 7.
9. Repeat steps 6 and 7, except send 2 SSD symbols, 1 Ternary symbol that does not represent SSD or valid Idle, 1 Idle symbol, and a valid frame in step 6. Increase the number of Idle symbols until the DUT is observed to accept the frame in step 7.

**Observable Results:**

- a. In step 2, the DUT should set RX\_ER=TRUE while in the BAD SSD state.
- b. In step 4, the DUT should set RX\_ER=TRUE while in the BAD SSD state.
- c. In step 5, the DUT should set RX\_ER=TRUE while in the BAD SSD state.



## OPEN Alliance

- d. In step 7, the DUT should accept the frame upon reception of 6 Idle symbols after the non-SSD and non-Idle symbol.
- e. In step 8, the DUT should accept the frame upon reception of 6 Idle symbols after the non-SSD and non-Idle symbol.
- f. In step 9, the DUT should accept the frame upon reception of 6 Idle symbols after the non-SSD and non-Idle symbol.

**Possible Problems:** This test cannot be performed if direct access to the DUT MII signals is not available.

## 8.6 Test 3.4.6 – Receive State Diagram - FIRST SSD State

**Purpose:** To verify that the DUT behaves properly while in the FIRST SSD state.

**References:**

- [1] OPEN Alliance BroadR-Reach Physical Layer Transceiver Specification For Automotive Applications Standard v3.2, Figure 3-7 – PCS Receive State Diagram

**Resource Requirements:**

- A test station capable of transmitting ternary symbols
- A test station capable of capturing the MII signals from the DUT

**Last Modification:** June 25, 2014 (version 1.3)

**Discussion:**

Reference [1] shows the valid transitions that a BroadR-Reach device can take through the PCS Receive State Diagram. Regardless of what is being received, once the DUT enters the FIRST SSD state it should set rx\_data = 101 and transition to the SECOND SSD state.

**Test Setup:** Connect the Device Under Test (DUT) to the test stations via the BroadR-Reach and MII interfaces.

**Procedure:**

1. Configure the test stations such that the DUT establishes a valid link while the test station is sending valid Idle.
2. Instruct the test station to send 3 SSD symbols followed by Ternary symbols for 010 and 101.
3. Monitor the MII transmissions from the DUT.
4. Repeat steps 2-3, except instruct the test station to send 3 SSD symbols followed by the Ternary symbols for 101 and 000 in step 2.
5. Repeat steps 2-3, except instruct the test station to send 3 SSD symbols followed by the Ternary symbols for 010 and SSD1 in step 2.

**Observable Results:**

- a. In step 2, the DUT should set RX\_DV=TRUE and RXD=0101.
- b. In step 4, the DUT should set RX\_DV=TRUE and RXD=0101.
- c. In step 5, the DUT should set RX\_DV=TRUE and RXD=0101.

**Possible Problems:** This test cannot be performed if direct access to the DUT MII signals is not available.

## 8.7 Test 3.4.7 – Receive State Diagram - SECOND SSD State

**Purpose:** To verify that the DUT behaves properly while in the SECOND SSD state.

**References:**

- [1] OPEN Alliance BroadR-Reach Physical Layer Transceiver Specification For Automotive Applications Standard v3.2, Figure 3-7 – PCS Receive State Diagram

**Resource Requirements:**

- A test station capable of transmitting ternary symbols
- A test station capable of capturing the MII signals from the DUT

**Last Modification:** June 25, 2014 (version 1.3)

**Discussion:**

Reference [1] shows the valid transitions that a BroadR-Reach device can take through the PCS Receive State Diagram. Regardless of what is being received, once the DUT enters the SECOND SSD state it should set rx\_data = 010 and transition to the THIRD SSD state.

**Test Setup:** Connect the Device Under Test (DUT) to the test stations via the BroadR-Reach and MII interfaces.

**Procedure:**

1. Configure the test stations such that the DUT establishes a valid link while the test station is sending valid Idle.
2. Instruct the test station to send 3 SSD symbols, and then Ternary symbols for 010, 101, and 010.
3. Monitor the MII transmissions from the DUT.
4. Repeat steps 2-3, except instruct the test station to send 3 SSD symbols, and then Ternary symbols for 010, 101, and 000 in step 2.
5. Repeat steps 2-3, except instruct the test station to send 3 SSD symbols, and then Ternary symbols for 010, 101, and the Ternary symbol for SSD1 in step 2.

**Observable Results:**

- a. In step 2, the DUT should set RX\_DV=TRUE and RXD=0101.
- b. In step 4, the DUT should set RX\_DV=TRUE and RXD=0101.
- c. In step 5, the DUT should set RX\_DV=TRUE and RXD=0101.

**Possible Problems:** This test cannot be performed if direct access to the DUT MII signals is not available.

## 8.8 Test 3.4.8 – Receive State Diagram - THIRD SSD State

**Purpose:** To verify that the DUT behaves properly while in the THIRD SSD state.

**References:**

- [1] OPEN Alliance BroadR-Reach Physical Layer Transceiver Specification For Automotive Applications Standard v3.2, Figure 3-7 – PCS Receive State Diagram

**Resource Requirements:**

- A test station capable of transmitting ternary symbols
- A test station capable of capturing the MII signals from the DUT

**Last Modification:** June 25, 2014 (version 1.3)

**Discussion:**

Reference [1] shows the valid transitions that a BroadR-Reach device can take through the PCS Receive State Diagram. Once the DUT enters the THIRD SSD state it should set rx\_data = 101 and transition to the CHECK ESD2 state if it receives ESD, or transition to the DATA state if it receives anything but ESD.

**Test Setup:** Connect the Device Under Test (DUT) to the test stations via the BroadR-Reach and MII interfaces.

**Procedure:**

1. Configure the test stations such that the DUT establishes a valid link while the test station is sending valid Idle.
2. Instruct the test station to send 3 SSD symbols, the Ternary symbols for 010, 101, 010, 101, 010, and several Ternary symbols representing data.
3. Monitor the MII transmissions from the DUT.
4. Repeat steps 2-3, except instruct the test station to send 3 SSD symbols, the Ternary symbols for 010 and 101, 010, and ESD1 in step 2.
5. Repeat steps 2-3, except instruct the test station to send 3 SSD symbols and several Ternary symbols for 000 in step 2.

**Observable Results:**

- a. In step 2, the DUT should set RX\_DV=TRUE and RXD=0101 for 6 clock cycles and then transmit data.
- b. In step 4, the DUT should set RX\_DV=TRUE and RXD=0101 for 4 clock cycles and then transmit xx01, where the value of x is undefined and up to the implementer.
- c. In step 5, the DUT should set RX\_DV=TRUE and RXD=0101 for 2 clock cycles, RXD=0001 for 1 clock cycle, and then several clock cycles of RXD=0000.

**Possible Problems:** This test cannot be performed if direct access to the DUT MII signals is not available.

## 8.9 Test 3.4.9 – Receive State Diagram - DATA State

**Purpose:** To verify that the DUT behaves properly while in the DATA state.

**References:**

- [1] OPEN Alliance BroadR-Reach Physical Layer Transceiver Specification For Automotive Applications Standard v3.2, Figure 3-7 – PCS Receive State Diagram

**Resource Requirements:**

- A test station capable of transmitting ternary symbols
- A test station capable of capturing the MII signals from the DUT

**Last Modification:** June 25, 2014 (version 1.3)

**Discussion:**

Reference [1] shows the valid transitions that a BroadR-Reach device can take through the PCS Receive State Diagram. Once the DUT enters the DATA state, it should not exit until it receives ESD1.

**Test Setup:** Connect the Device Under Test (DUT) to the test stations via the BroadR-Reach and MII interfaces.

**Procedure:**

1. Configure the test stations such that the DUT establishes a valid link while the test station is sending valid Idle.
2. Instruct the test station to send 3 SSD symbols, the Ternary symbols for 010, 101, 010, 101, 010, and several Ternary symbols representing data, followed by ESD1.
3. Monitor the MII transmissions from the DUT.
4. Repeat steps 2-3, except instruct the test station to send 3 SSD symbols, the Ternary symbols for 010, 101, 010, and ESD1 in step 2.
5. Repeat step 4, sending additional data before the ESD1 in step 2.

**Observable Results:**

- a. In step 2, the DUT should set RX\_DV=TRUE and RXD=0101 for 6 clock cycles and then transmit data before setting RX\_DV=FALSE and RXD=0000.
- b. In step 4, the DUT should set RX\_DV=TRUE and RXD=0101 for 4 clock cycles.
- c. In step 5, the DUT should set RX\_DV=TRUE and RXD=0101 for 4 clock cycles and transmit the data sent before the ESD.

**Possible Problems:** In step 5 the DUT may not transmit 1 or 2 of the bits sent prior to the ESD because they may be received as stuff bits during the 3B4B conversion. This test cannot be performed if direct access to the DUT MII signals is not available.

## 8.10 Test 3.4.10 – Receive State Diagram - CHECK ESD2 State

**Purpose:** To verify that the DUT behaves properly while in the CHECK ESD2 state.

**References:**

- [1] OPEN Alliance BroadR-Reach Physical Layer Transceiver Specification For Automotive Applications Standard v3.2, Figure 3-7 – PCS Receive State Diagram

**Resource Requirements:**

- A test station capable of transmitting ternary symbols
- A test station capable of capturing the MII signals from the DUT

**Last Modification:** June 25, 2014 (version 1.3)

**Discussion:**

Reference [1] shows the valid transitions that a BroadR-Reach device can take through the PCS Receive State Diagram. Once the DUT enters the CHECK ESD2 state, it should transition to CHECK ESD3 upon reception of ESD2 or transition to BAD END if it receives anything other than ESD2.

**Test Setup:** Connect the Device Under Test (DUT) to the test stations via the BroadR-Reach and MII interfaces.

**Procedure:**

1. Configure the test stations such that the DUT establishes a valid link while the test station is sending valid Idle.
2. Instruct the test station to send 3 SSD symbols, the Ternary symbols for 010, 101, 010, 101, 010, and several Ternary symbols representing data, followed by ESD1, ESD2, and ESD3.
3. Monitor the MII transmissions from the DUT.
4. Repeat steps 2-3, except instruct the test station to send 3 SSD symbols, the Ternary symbols for 010, 101, 010, 101, 010, ESD1, and the Ternary symbol for 000 in step 2.
5. Repeat steps 2-3, except instruct the test station to send 3 SSD symbols, the Ternary symbols for 010, 101, 010, 101, 010, ESD1, and ESD3 in step 2.

**Observable Results:**

- a. In step 2, the DUT should set RX\_DV=TRUE and RXD=0101 for 6 clock cycles and then transmit data, before setting RX\_DV=FALSE and RXD=0000.
- b. In step 4, the DUT should set RX\_DV=TRUE and RXD=0101 for 4 clock cycles, and then set RX\_ER=TRUE.
- c. In step 5, the DUT should set RX\_DV=TRUE and RXD=0101 for 4 clock cycles, and then set RX\_ER=TRUE.

**Possible Problems:** This test cannot be performed if direct access to the DUT MII signals is not available.

## 8.11 Test 3.4.11 – Receive State Diagram - CHECK ESD3 State

**Purpose:** To verify that the DUT behaves properly while in the CHECK ESD3 state.

**References:**

- [1] OPEN Alliance BroadR-Reach Physical Layer Transceiver Specification For Automotive Applications Standard v3.2, Figure 3-7 – PCS Receive State Diagram

**Resource Requirements:**

- A test station capable of transmitting ternary symbols
- A test station capable of capturing the MII signals from the DUT

**Last Modification:** September 18, 2014 (version 1.4)

**Discussion:**

Reference [1] shows the valid transitions that a BroadR-Reach device can take through the PCS Receive State Diagram. Once the DUT enters the CHECK ESD3 state, it should transition to ESD upon reception of ESD3 or, RX ERROR upon reception of ERR\_ESD3, or BAD END if it receives anything else.

**Test Setup:** Connect the Device Under Test (DUT) to the test stations via the BroadR-Reach and MII interfaces.

**Procedure:**

1. Configure the test stations such that the DUT establishes a valid link while the test station is sending valid Idle.
2. Instruct the test station to send 3 SSD symbols, the Ternary symbols for 010, 101, 010, 101, 010, and several Ternary symbols representing data, followed by ESD1, ESD2, and ESD3.
3. Monitor the MII transmissions from the DUT.
4. Repeat steps 2-3, except instruct the test station to send 3 SSD symbols, the Ternary symbols for 010, 101, 010, 101, 010, ESD1, ESD2, and ERR\_ESD3 in step 2.
5. Repeat steps 2-3, except instruct the test station to send 3 SSD symbols, the Ternary symbols for 010, 101, 010, 101, 010, ESD1, ESD2, and the Ternary symbol for 000 in step 2.
6. Repeat steps 2-3, except instruct the test station to send 3 SSD symbols, the Ternary symbols for 010, 101, 010, 101, 010, ESD1, ESD2, ESD2, and ESD3 in step 2.

**Observable Results:**

- a. In step 2, the DUT should set RX\_DV=TRUE and RXD=0101 for 6 clock cycles and then transmit data, before setting RX\_DV=FALSE and RXD=0000.
- b. In step 4, the DUT should set RX\_DV=TRUE and RXD=0101 for 5 clock cycles, and then set RX\_ER=TRUE.
- c. In step 5, the DUT should set RX\_DV=TRUE and RXD=0101 for 5 clock cycles, and then set RX\_ER=TRUE.
- d. In step 6, the DUT should set RX\_DV=TRUE and RXD=0101 for 5 clock cycles, and then set RX\_ER=TRUE.

**Possible Problems:** This test cannot be performed if direct access to the DUT MII signals is not available.

## 8.12 Test 3.4.12 – Receive State Diagram - BAD ESD2 State

**Purpose:** To verify that the DUT behaves properly while in the BAD ESD2 state.

**References:**

- [1] OPEN Alliance BroadR-Reach Physical Layer Transceiver Specification For Automotive Applications Standard v3.2, Figure 3-7 – PCS Receive State Diagram

**Resource Requirements:**

- A test station capable of transmitting ternary symbols
- A test station capable of capturing the MII signals from the DUT

**Last Modification:** June 25, 2014 (version 1.3)

**Discussion:**

Reference [1] shows the valid transitions that a BroadR-Reach device can take through the PCS Receive State Diagram. Once the DUT enters the BAD ESD2 state, it should set RX\_ER = TRUE and transition to BAD END regardless of what is received.

**Test Setup:** Connect the Device Under Test (DUT) to the test stations via the BroadR-Reach and MII interfaces.

**Procedure:**

1. Configure the test stations such that the DUT establishes a valid link while the test station is sending valid Idle.
2. Instructing the test station to send 3 SSD symbols, the Ternary symbols for 010, 101, 010, 101, 010, ESD1, and the Ternary symbol for 000 twice.
3. Monitor the MII transmissions from the DUT.
4. Repeat steps 2-3, except instruct the test station to send 3 SSD symbols, the Ternary symbols for 010, 101, 010, 101, 010, ESD1, the Ternary symbol for 000, and ESD3 in step 2.
5. Repeat steps 2-3, except instruct the test station to send 3 SSD symbols, the Ternary symbols for 010, 101, 010, 101, 010, ESD1, the Ternary symbol for 000, and SSD in step 2.

**Observable Results:**

- a. In step 2, the DUT should set RX\_DV=TRUE and RXD=0101 for 4 clock cycles, and then set RX\_ER=TRUE for 2 clock cycles.
- b. In step 4, the DUT should set RX\_DV=TRUE and RXD=0101 for 4 clock cycles, and then set RX\_ER=TRUE for 2 clock cycles.
- c. In step 5, the DUT should set RX\_DV=TRUE and RXD=0101 for 4 clock cycles, and then set RX\_ER=TRUE for 2 clock cycles.

**Possible Problems:** This test cannot be performed if direct access to the DUT MII signals is not available.



## 8.13 Test 3.4.13 – Receive State Diagram - BAD END and RX ERROR states

**Purpose:** To verify that the DUT behaves properly while in the BAD END or RX ERROR states.

**References:**

- [1] OPEN Alliance BroadR-Reach Physical Layer Transceiver Specification For Automotive Applications Standard v3.2, Figure 3-7 – PCS Receive State Diagram

**Resource Requirements:**

- A test station capable of transmitting ternary symbols
- A test station capable of capturing the MII signals from the DUT

**Last Modification:** September 18, 2014 (version 1.4)

**Discussion:**

Reference [1] shows the valid transitions that a BroadR-Reach device can take through the PCS Receive State Diagram. Once the DUT enters the BAD END or RX ERROR state, it should set RX\_ER=TRUE and transition to IDLE regardless of what is received.

**Test Setup:** Connect the Device Under Test (DUT) to the test stations via the BroadR-Reach and MII interfaces.

**Procedure:**

1. Configure the test stations such that the DUT establishes a valid link while the test station is sending valid Idle.
2. Instruct the test station to send 3 SSD symbols, the Ternary symbols for 010, 101, 010, 101, 010, ESD1, ESD2, and ERR ESD3.
3. Monitor the MII transmissions from the DUT.
4. Repeat steps 2-3, except instruct the test station to send 3 SSD symbols, the Ternary symbols for 010, 101, 010, 101, 010, ESD1, ESD2, and all ternary symbols that do not represent ESD3 or ERR\_ESD3 in step 2.
5. Repeat steps 2-3, except instruct the test station to send 3 SSD symbols, the Ternary symbols for 010, 101, 010, 101, 010, ESD1, ESD2, and SSD in step 2.

**Observable Results:**

- a. In step 2, the DUT should set RX\_DV=TRUE and RXD=0101 for 5 clock cycles, and then set RX\_ER=TRUE for 1 clock cycle.
- b. In step 4, the DUT should set RX\_DV=TRUE and RXD=0101 for 5 clock cycles, and then set RX\_ER=TRUE for 1 clock cycle.
- c. In step 5, the DUT should set RX\_DV=TRUE and RXD=0101 for 5 clock cycles, and then set RX\_ER=TRUE for 1 clock cycle.

**Possible Problems:** This test cannot be performed if direct access to the DUT MII signals is not available.

## 9 GROUP 5: JAB State Diagram

### Overview:

The tests defined in this section verify the JAB State Diagram defined for BroadR-Reach capable PHYs in section 3.3 of the OPEN Alliance BroadR-Reach Physical Layer Transceiver Specification For Automotive Applications Standard v3.2.

## 9.1 Test 3.5.1 – JAB State Diagram - rcv\_max\_timer

**Purpose:** To verify that the DUT properly implements a rcv\_max\_timer of 34,200 - 37,800 pcs\_rxclk clock cycles.

**References:**

- [1] OPEN Alliance BroadR-Reach Physical Layer Transceiver Specification For Automotive Applications Standard v3.2, Figure 3-8 – JAB State Diagram
- [2] Ibid., Figure 3-7 – PCS Receive State Diagram
- [3] Ibid., section 3.3.1.1 - Variables

**Resource Requirements:**

- A test station capable of transmitting ternary symbols
- A test station capable of capturing the MII signals from the DUT

**Last Modification:** June 25, 2014 (version 1.3)

**Discussion:**

Reference [1] shows the valid transitions that a BroadR-Reach device can take through the JAB State Diagram. Once the DUT sets receiving=TRUE it enters the MONJAB state and starts the rcv\_max\_timer. Upon expiration of the timer, the DUT transitions to the JAB state, which causes the PCS Receive State Diagram to transition to the IDLE state. The value of rcv\_max\_timer should be within the range of 34,200 - 37,800 pcs\_rxclk clock cycles.

This test will be performed by sending a very large packet that is terminated with ESD1, ESD2, and ERR\_ESD3. If the frame is not long enough to cause a transition to the JAB state then the PCS Receive State Diagram will transition to the RX ERROR state and set pcs\_rx\_er =TRUE for one clock cycle while pcs\_rx\_dv =TRUE. If the frame is long enough to cause a transition to the JAB state then the PCS Receive State Diagram will transition directly to the IDLE state where it sets pcs\_rx\_dv=FALSE. The remaining frame data and/or ESD symbols will cause a transition to the BAD SSD state where the DUT will set pcs\_rx\_er=TRUE while pcs\_rx\_dv=FALSE.

**Test Setup:** Connect the Device Under Test (DUT) to the test stations via the BroadR-Reach and MII interfaces.

**Procedure:**

1. Configure the test stations such that the DUT establishes a valid link while the test station is sending valid Idle.
2. Instruct the test station to send Preamble and frame data for 34,200 clock cycles, followed by ESD1, ESD2, and ERR\_ESD3.
3. Monitor the MII transmissions from the DUT.
4. Repeat steps 2-3, increasing the amount of data until the PCS Receive State Diagram transitions directly to the IDLE state.

**Observable Results:**

- a. The DUT should implement a rcv\_max\_timer within the range of 34,200 - 37,800 pcs\_rxclk clock cycles.

**Possible Problems:** This test cannot be performed if direct access to the DUT MII signals is not available.

## 10 TEST SUITE APPENDICES

### **Overview:**

The appendices contained in this section are intended to provide additional low-level technical details pertinent to specific tests defined in this test suite. Test suite appendices often cover topics that are beyond the scope of the standard, but are specific to the methodologies used for performing the measurements covered in this test suite. This may also include details regarding a specific interpretation of the standard (for the purposes of this test suite), in cases where a specification may appear unclear or otherwise open to multiple interpretations.

### **Scope:**

Test suite appendices are considered informative, and pertain only to tests contained in this test suite.

## 10.1 Appendix 3.A –Testing Devices Without MII Access

**Purpose:** To detail the tests that can be performed on a device without MII access, and to detail the modifications to the Procedures and Observable Results.

**Discussion:** The amount of tests that can be performed on a device without MII access is reduced. Typically, the only observation points that will be available packet counters or packets that are forwarded through another port on the DUT. Also, the only transmissions available from the DUT will be Training, Idle, and packets. The following table lists all tests and if they are possible with or without modification. The necessary modifications are detailed in the following sections.

Test Name	IOL Test Number	No Modification Required	Requires Modification	Cannot be Tested
<b>Group 1: PCS Transmit</b>				
PCS Signaling	Test 3.1.1	All Parts		
PCS Reset	Test 3.1.2	All Parts		
Transmit Proper SSD	Test 3.1.3	All Parts		
Transmit Proper ESD	Test 3.1.4	All Parts		
Transmit ESD with tx_error	Test 3.1.5			All Parts
Transmission of Stuff Bits	Test 3.1.6	All Parts		
Tx_error	Test 3.1.7			All Parts
<b>Group 2: PCS Transmit State Diagram</b>				
Transmit State Diagram - SEND IDLE state	Tests 3.2.1		c	a, b, d
Transmit State Diagram - SSD1 VECTOR and SSD2 VECTOR states	Tests 3.2.2		a	b, c, d, e
Transmit State Diagram - SSD3 VECTOR state	Tests 3.2.3		a	b, c, d, e
Transmit State Diagram - TRANSMIT DATA state	Tests 3.2.4		a	b, c, d, e
Transmit State Diagram - ESD1 VECTOR state	Tests 3.2.5		a	b
Transmit State Diagram - ESD2 VECTOR state	Tests 3.2.6		a	b
Transmit State Diagram - ESD3 VECTOR state	Tests 3.2.7		a	
Transmit State Diagram - ERR ESD1 VECTOR state	Tests 3.2.8			All Parts
Transmit State Diagram - ERR ESD2 VECTOR state	Tests 3.2.9			All Parts
Transmit State Diagram - ERR ESD2 VECTOR state	Tests 3.2.10			All Parts
<b>Group 3: PCS Receive</b>				
Receive PCS Signaling	Test 3.3.1	All Parts		
Automatic Polarity Detection (Optional)	Test 3.3.2	All Parts		
Receive SSD	Test 3.3.3	All Parts		
Receive ESD	Test 3.3.4	All Parts		
Receive ERR_ESD3	Test 3.3.5	All Parts		
Reception of Stuff Bits	Test 3.3.6	All Parts		
De-Interleave Ternary Pairs	Test 3.3.7	All Parts		
<b>Group 4: PCS Receive State Diagram</b>				
Receive State Diagram - IDLE State	Test 3.4.1		a, b	
Receive State Diagram - CHECK SSD2 State	Test 3.4.2		a, b	
Receive State Diagram - CHECK SSD3 State	Test 3.4.3		a, b	
Receive State Diagram -SSD State	Test 3.4.4		a	b, c
Receive State Diagram - BAD SSD State	Test 3.4.5		d, e, f	a, b, c
Receive State Diagram - FIRST SSD State	Test 3.4.6		a	b, c
Receive State Diagram - SECOND SSD State	Test 3.4.7		a	b, c
Receive State Diagram - THIRD SSD State	Test 3.4.8		a	b, c
Receive State Diagram - DATA State	Test 3.4.9		a	b, c
Receive State Diagram - CHECK ESD2 State	Test 3.4.10		All Parts	
Receive State Diagram - CHECK ESD3 State	Test 3.4.11		All Parts	
Receive State Diagram - BAD ESD2 State	Test 3.4.12		All Parts	
Receive State Diagram - BAD END and RX ERROR States	Test 3.4.13		All Parts	
<b>Group 5: JAB State Diagram</b>				
JAB State Diagram - rcv_max_timer	Test 3.5.1			All Parts

**Table 3A. 1 - Tests that are possible without MII access**

### 10.1.1 Test 3.2.1 – PCS Transmit State Diagram - SEND IDLE State

**Procedure:**

1. Configure the test station and Link Partner such that the DUT establishes a valid link.
2. Instruct the DUT to transmit a valid packet.
3. Monitor the transmissions from the DUT.

**Observable Results:**

- c. In step 2, the DUT should transmit valid SSD1.

### 10.1.2 Test 3.2.2 – PCS Transmit State Diagram - SSD1 VECTOR and SSD2 VECTOR states

**Procedure:**

1. Configure the test station and Link Partner such that the DUT establishes a valid link.
2. Instruct the DUT to transmit a valid packet.
3. Monitor the transmissions from the DUT.

**Observable Results:**

- a. In step 2, the DUT should transmit valid SSD1, SSD2, and SSD3.

### 10.1.3 Test 3.2.3 – PCS Transmit State Diagram - SSD3 VECTOR state

**Procedure:**

1. Configure the test station and Link Partner such that the DUT establishes a valid link.
2. Instruct the DUT to transmit a valid packet.
3. Monitor the transmissions from the DUT.

**Observable Results:**

- a. In step 2, the DUT should transmit valid SSD3 and frame data.

### 10.1.4 Test 3.2.4 – PCS Transmit State Diagram - TRANSMIT DATA state

**Procedure:**

1. Configure the test station and Link Partner such that the DUT establishes a valid link.
2. Instruct the DUT to transmit a valid packet.
3. Monitor the transmissions from the DUT.

**Observable Results:**

- a. In step 2, the DUT should transmit valid frame data and ESD.



### 10.1.5 Test 3.2.5 – PCS Transmit State Diagram - ESD1 VECTOR state

**Procedure:**

1. Configure the test station and Link Partner such that the DUT establishes a valid link.
2. Instruct the DUT to transmit a valid packet.
3. Monitor the transmissions from the DUT.

**Observable Results:**

- a. In step 2, the DUT should transmit valid ESD1 and ESD2.

### 10.1.6 Test 3.2.6 – PCS Transmit State Diagram - ESD2 VECTOR state

**Procedure:**

1. Configure the test station and Link Partner such that the DUT establishes a valid link.
2. Instruct the DUT to transmit a valid packet.
3. Monitor the transmissions from the DUT.

**Observable Results:**

- a. In step 2, the DUT should transmit valid ESD2 and ESD3.

### 10.1.7 Test 3.2.7 – PCS Transmit State Diagram - ESD3 VECTOR state

**Procedure:**

1. Configure the test station and Link Partner such that the DUT establishes a valid link.
2. Instruct the DUT to transmit a valid packet.
3. Monitor the transmissions from the DUT.

**Observable Results:**

- a. In step 2, the DUT should transmit valid ESD3 followed by Idle.

### 10.1.8 Test 3.4.1 – Receive State Diagram - IDLE State

**Procedure:**

1. Configure the test stations such that the DUT establishes a valid link while the test station is sending valid Idle.
2. Instruct the test station to send a valid packet.
3. Monitor the DUT to determine if the DUT accepted the packet.
4. Repeat steps 1-3, except instruct the test station to send a Ternary symbol that does not represent SSD1 or valid Idle, followed by 1 Idle symbol and a valid packet in step 2.

**Observable Results:**

- a. In step 2, the DUT should receive the packet.
- b. In step 4, the DUT should not receive the packet.

### 10.1.9 Test 3.4.2 – Receive State Diagram - CHECK SSD2 State

**Procedure:**

1. Configure the test stations such that the DUT establishes a valid link while the test station is sending valid Idle.
2. Instruct the test station to send a valid packet.
3. Monitor the DUT to determine if the DUT accepted the packet.
4. Repeat steps 1-3, except instruct the test station to send SSD1 and a Ternary symbol that does not represent SSD2, followed by 1 Idle symbol and a valid packet in step 2.
5. Repeat steps 1-3, except instruct the test station to transmit a packet where SSD2 of an otherwise valid packet is replaced with a Ternary symbol that does not represent SSD2.

**Observable Results:**

- a. In step 2, the DUT should receive the packet.
- b. In steps 4 and 5, the DUT should not receive the packet.

### 10.1.10 Test 3.4.3 – Receive State Diagram - CHECK SSD3 State

**Procedure:**

1. Configure the test stations such that the DUT establishes a valid link while the test station is sending valid Idle.
2. Instruct the test station to send a valid packet.
3. Monitor the DUT to determine if the DUT accepted the packet.
4. Repeat steps 1-3, except instruct the test station to send SSD1, SSD2, and a Ternary symbol that does not represent SSD3, followed by 1 Idle symbol and a valid packet in step 2.
5. Repeat steps 1-3, except instruct the test station to transmit a packet where SSD3 of an otherwise valid packet is replaced with a Ternary symbol that does not represent SSD3 in step 2.

**Observable Results:**

- a. In step 2, the DUT should receive the packet.
- b. In steps 4 and 5, the DUT should not receive the packet.

### 10.1.11 Test 3.4.4 – Receive State Diagram - SSD State

**Procedure:**

1. Configure the test stations such that the DUT establishes a valid link while the test station is sending valid Idle.
2. Instruct the test station to send a valid packet.
3. Monitor the DUT to determine if the DUT accepted the packet.

**Observable Results:**

- a. In step 2, the DUT should receive the packet.

### 10.1.12 Test 3.4.5 – Receive State Diagram - BAD SSD State

**Procedure:**

1. Configure the test stations such that the DUT establishes a valid link while the test station is sending valid Idle.
2. Instruct the test station to send a Ternary symbols that does not represent SSD or valid Idle, followed by 1 Idle symbol and a valid packet.
3. Monitor the DUT to determine if the DUT accepted the packet.
4. Repeat steps 2-3, sending additional Idle before the packet until the DUT is observed to accept the frame.
5. Repeat steps 1-4, except instruct the test station to send 1 SSD symbol followed by 1 Ternary symbols that does not represent SSD or valid Idle, followed by 1 Idle symbol and a valid packet in step 2. Increase the number of Idle symbols until the DUT is observed to accept the frame.
6. Repeat steps 1-4, except instruct the test station to send 2 SSD symbols followed by 1 Ternary symbols that does not represent SSD or valid Idle, followed by 1 Idle symbol and a valid packet in step 2. Increase the number of Idle symbols until the DUT is observed to accept the frame.

**Observable Results:**

- d. In step 4, the DUT should accept the frame upon reception of 6 Idle symbols after the non-SSD and non-Idle symbol.
- e. In step 5, the DUT should accept the frame upon reception of 6 Idle symbols after the non-SSD and non-Idle symbol.
- f. In step 6, the DUT should accept the frame upon reception of 6 Idle symbols after the non-SSD and non-Idle symbol.

### 10.1.13 Test 3.4.6 – Receive State Diagram - FIRST SSD State

**Procedure:**

4. Configure the test stations such that the DUT establishes a valid link while the test station is sending valid Idle.
5. Instruct the test station to send a valid packet.
6. Monitor the DUT to determine if the DUT accepted the packet.

**Observable Results:**

- b. In step 2, the DUT should receive the packet.

### 10.1.14 Test 3.4.7 – Receive State Diagram - SECOND SSD State

**Procedure:**

1. Configure the test stations such that the DUT establishes a valid link while the test station is sending valid Idle.
2. Instruct the test station to send a valid packet.
3. Monitor the DUT to determine if the DUT accepted the packet.

**Observable Results:**

- a. In step 2, the DUT should receive the packet.

### 10.1.15 Test 3.4.8 – Receive State Diagram - THIRD SSD State

**Procedure:**

1. Configure the test stations such that the DUT establishes a valid link while the test station is sending valid Idle.
2. Instruct the test station to send a valid packet.
3. Monitor the DUT to determine if the DUT accepted the packet.

**Observable Results:**

- a. In step 2, the DUT should receive the packet.

### 10.1.16 Test 3.4.9 – Receive State Diagram - DATA State

**Procedure:**

1. Configure the test stations such that the DUT establishes a valid link while the test station is sending valid Idle.
2. Instruct the test station to send a valid packet.
3. Monitor the DUT to determine if the DUT accepted the packet.

**Observable Results:**

- a. In step 2, the DUT should receive the packet.

### 10.1.17 Test 3.4.10 – Receive State Diagram - CHECK ESD2 State

**Procedure:**

1. Configure the test stations such that the DUT establishes a valid link while the test station is sending valid Idle.
2. Instruct the test station to send a valid packet.
3. Monitor the DUT to determine if the DUT accepted the packet.
4. Repeat steps 1-3, except instruct the test station to send preamble and valid frame data followed by ESD1, the Ternary symbol for 000, ESD2, and ESD3 in step 2.
5. Repeat steps 1-3, except instruct the test station to send preamble and valid frame data followed by ESD1, ESD3, ESD2, and ESD3 in step 2.

**Observable Results:**

- a. In step 2, the DUT should receive the packet.
- b. In step 4, the DUT should indicate the reception of an errored packet.
- c. In step 5, the DUT should indicate the reception of an errored packet.

### 10.1.18 Test 3.4.11– Receive State Diagram - CHECK ESD3 State

**Procedure:**

1. Configure the test stations such that the DUT establishes a valid link while the test station is sending valid Idle.
2. Instruct the test station to send a valid packet.
3. Monitor the DUT to determine if the DUT accepted the packet.
4. Repeat steps 1-3, except instruct the test station to send preamble and valid frame data followed by ESD1, ESD2, and ERR\_ESD3 in step 2.
5. Repeat steps 1-3, except instruct the test station to send preamble and valid frame data followed by ESD1, ESD2, the Ternary symbol for 000, and ESD3 in step 2.
6. Repeat steps 1-3, except instruct the test station to send preamble and valid frame data followed by ESD1, ESD2, ESD2, and ESD3 in step 2.

**Observable Results:**

- a. In step 2, the DUT should receive the packet.
- b. In step 4, the DUT should indicate the reception of an errored packet.
- c. In step 5, the DUT should indicate the reception of an errored packet.
- d. In step 6, the DUT should indicate the reception of an errored packet.

### 10.1.19 Test 3.4.12 – Receive State Diagram - BAD ESD2 State

**Procedure:**

1. Configure the test stations such that the DUT establishes a valid link while the test station is sending valid Idle.
2. Instruct the test station to send preamble and valid frame data followed by ESD1 and the Ternary symbol for 000 twice.
3. Monitor the DUT to determine if the DUT accepted the packet.
4. Repeat steps 1-3, except instruct the test station to send preamble and valid frame data followed by ESD1, the Ternary symbol for 000, and ESD3 in step 2.
5. Repeat steps 1-3, except instruct the test station to send preamble and valid frame data followed by ESD1, the Ternary symbol for 000, and SSD in step 2.

**Observable Results:**

- a. In step 2, the DUT should indicate the reception of an errored packet.
- b. In step 4, the DUT should indicate the reception of an errored packet.
- c. In step 5, the DUT should indicate the reception of an errored packet.

## 10.1.20 Test 3.4.13 – Receive State Diagram - BAD END and RX ERROR states

### Procedure:

1. Configure the test stations such that the DUT establishes a valid link while the test station is sending valid Idle.
2. Instruct the test station to send preamble and valid frame data followed by ESD1, ESD2, and ERR\_ESD3.
3. Monitor the DUT to determine if the DUT accepted the packet.
4. Repeat steps 1-3, except instruct the test station to send preamble and valid frame data followed by ESD1, ESD2, and all ternary symbols that do not represent ESD3 or ERR\_ESD3 in step 2.
5. Repeat steps 1-3, except instruct the test station to send preamble and valid frame data followed by ESD1, ESD2, and SSD in step 2.

### Observable Results:

- a. In step 2, the DUT should indicate the reception of an errored packet.
- b. In step 4, the DUT should indicate the reception of an errored packet.
- c. In step 5, the DUT should indicate the reception of an errored packet.

## 10.2 Appendix 3.B – Test Stations

**Purpose:** To provide the requirements of the test stations used during BroadR-Reach PCS testing.

**Discussion:**

Two test stations will be required to perform all tests that are specified in this document. The BroadR-Reach Receive Test Station will examine the transmissions from the DUT, and the BroadR-Reach Transmit Test Station will transmit the necessary test patterns to test the receiver of the DUT. It is possible to combine both stations into one setup.

The BroadR-Reach Receive Test Station will consist of an oscilloscope and software to capture and decode the transmissions from the DUT. The DUT will connect to the test station through the Line Tap as specified in appendix 3.B. The software will download the capture from the oscilloscope and decode the ternary symbols, using knowledge of the BroadR-Reach encoding, to create the MII data stream. The test setup is shown in Figure A - 1. Note that the MII test station is mandatory for some tests, while it can be replaced with higher layers or a loopback in some tests. Other solutions, such as an FPGA that can capture the ternary symbols, are possible however the test station must not modify or affect the transmissions from the DUT in any manner.

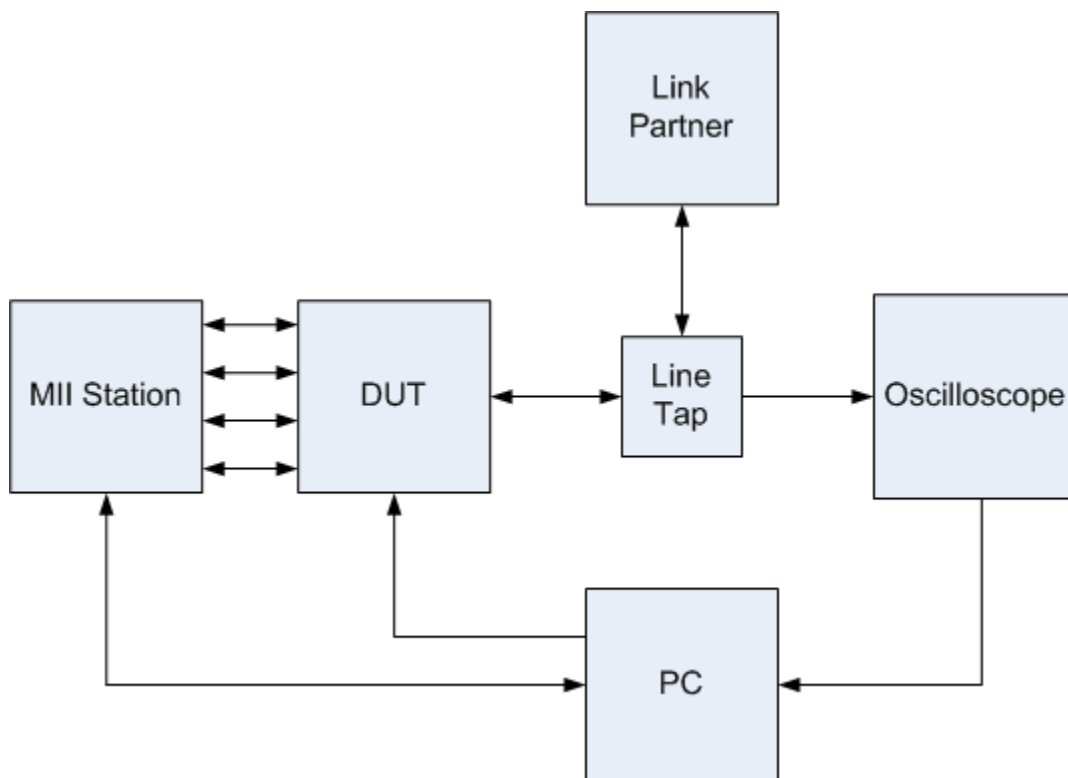

**Figure A - 1: BroadR-Reach Receive Station Setup**

The BroadR-Reach Transmit Test Station will consist of software and hardware that is capable of transmitting arbitrary ternary symbols to the DUT. The ability to send arbitrary sequences, such as invalid transitions of the PCS Transmit State Machine, is essential to fully test the receiver of the DUT.

The test setup is shown in Figure A - 2. Note that the MII test station is mandatory for some tests, while it can be replaced with higher layers or a loopback in some tests.

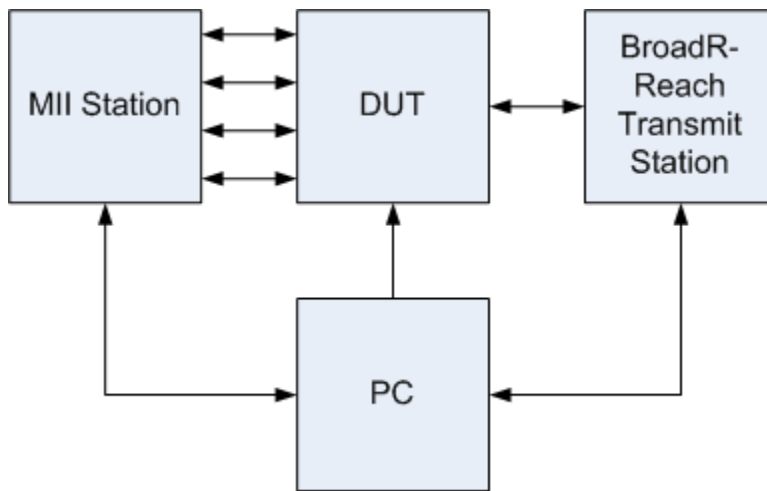

**Figure A - 2: BroadR-Reach Transmit Station Setup**



### 10.3 Appendix 3.C – Line Tap

**Purpose:** To provide the requirements of a line tap that will be used, in conjunction with an oscilloscope, to capture the transmissions from the DUT.

**Discussion:** For information on the line tap used during BroadR-Reach PCS testing, please contact the UNH-IOL.