



UNH-IOL
DSL Consortium
Broadband Forum TR-067
(TR067) Report Revision 1.0

UNH-IOL — 121 Technology Drive, Suite 2 — Durham, NH 03824 — +1-603-862-2911			
DSL Manager	Jason Walls	jwalls@iol.unh.edu	+1-603-862-5051
Technician	Joe Tester	joe@iol.unh.edu	+1-603-862-2911
Reviewed by	Jane Tester	jane@iol.unh.edu	+1-603-862-2911

14 April 2009

Mr. Mike Vendor
DSL Consortium
121 Technology Drive, Suite 2
Durham, NH 03824
mike@dsltechnologies.edu
+1-555-555-5555

Mr. Vendor,

Enclosed are the results from the Broadband Forum TR-067 Test Suite performed on the DSL Consortium Model A CPE. The testing was performed according to Version 2 of the Broadband Forum TR-067, which may be downloaded from the following address:

<http://www.broadband-forum.org/technical/download/TR-067Issue2.pdf>

If you have any questions about the test procedures or results, please contact me via email at joe@iol.unh.edu, or by phone at +1-603-862-2911.

Sincerely,

Joe Tester

Joe Tester

Report reviewed by

Jane Tester

Jane Tester

Digital Signature Information

This document was created using an Adobe digital signature. A digital signature helps to ensure the authenticity of the document, but only in this digital format. For information on how to verify this document's integrity proceed to the following site:

<http://www.iol.unh.edu/certifyDoc>

If the document status still indicates "Validity of author NOT confirmed", then please contact the UNH-IOL to confirm the document's authenticity. To further validate the certificate integrity, Adobe 6.0 should report the following fingerprint information:

MD5 Fingerprint: A303 D24B 3F7D 0E0D 27F2 B8BC 5FA0 1FC6
SHA-1 Fingerprint: 7BD1 A2EE 89DC AB98 2E32 F36A A9E6 E865 A0EE 88EE

Sample Report

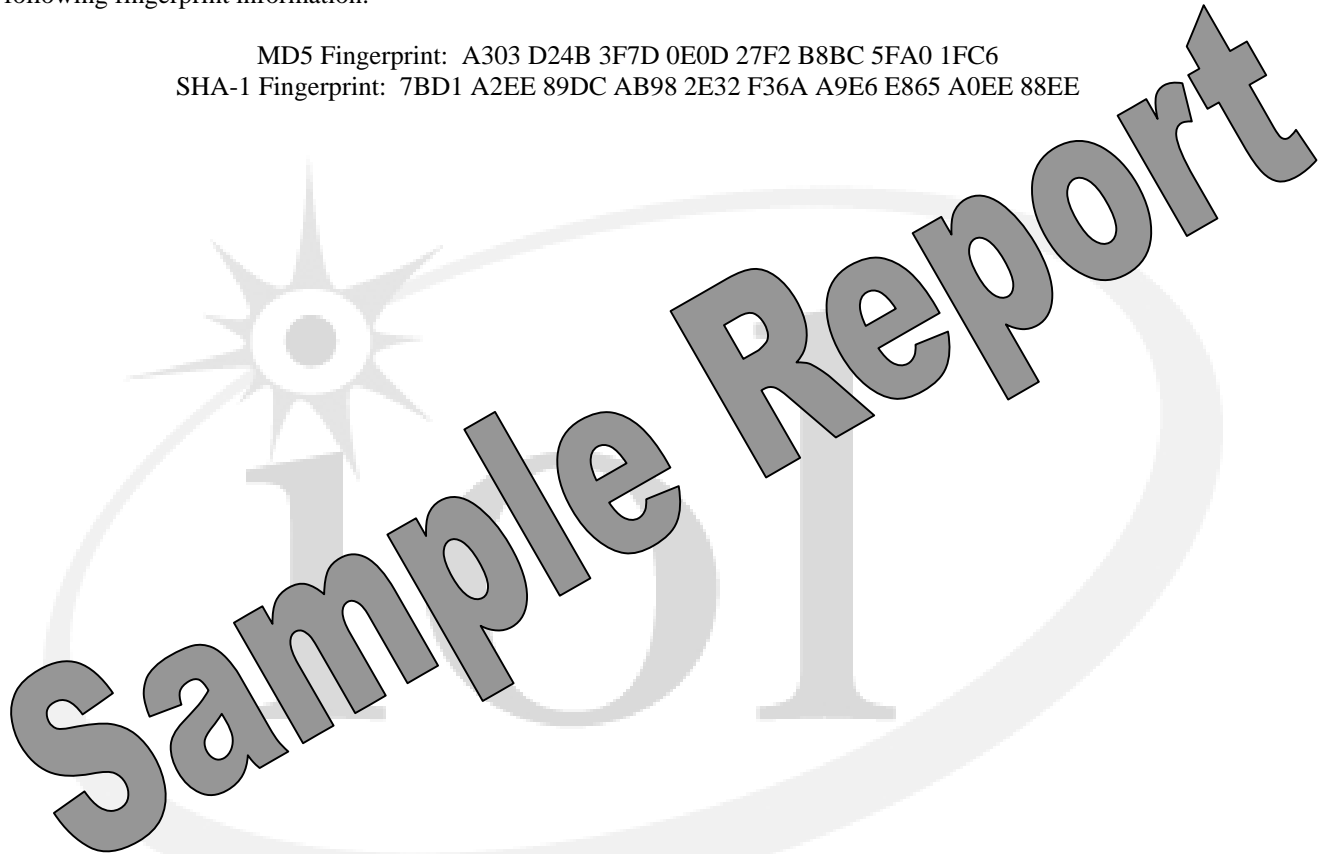

Result Key

Result	Interpretation
PASS	The device under test (DUT) exhibited conformant behavior.
FAIL	The DUT exhibited non-conformant behavior.
RTC	(Refer-to-Comments) – From the observations a valid pass or fail could not be determined. Additional information explaining the situation is included.
NA	(Not Applicable) – The DUT does not support the technology required to perform this test.
NT	(Not Tested) – This test was not performed. Please refer to comments for a detailed explanation.

Sample Report



Test Summary

Test Number	Test Name	Results
SECTION 8 – PHYSICAL LAYER TEST CASES		
8.1	ADSL Functionality Tests	FAIL
8.2	Sudden Application of RFI	PASS
8.4	Stress Test	PASS
8.5	Electrical Compatibility Tests	PASS
SECTION 9 – HIGHER LAYER TEST CASES		
9.1	ATM Connectivity Tests	PASS
9.2	Packet Throughput Test	NT
9.3	RFC 2516 [11] PPPoE End-to-End Connectivity Test	PASS
9.4	RFC 2364 [12] PPPoA End-to-End Connectivity Test	PASS
9.5	RFC 2684 [10] End-to-End Connectivity Test	PASS
9.6	Usability Test	NT
ANNEX A - PHYSICAL LAYER TEST CASES FOR SYSTEMS USING G.992.1 ANNEX A		
A.1.2	ANSI T1-413 Operation	FAIL
A.1.5	Loop Tests with Ports Set for Adaptive Rate	FAIL
A.1.6	Loop Tests with Ports Set for Fixed Rate	PASS
A.1.7	CSA #4 Standard Loop	FAIL
A.1.8	ANSI 13 Standard Loop	FAIL
A.1.9	Bridged Tap Tests	FAIL
A.2.3.1	European Loops - White Noise Impairment - Variable Rate	PASS
A.2.3.2	European Loops - FB Impairment - Variable Rate	PASS
A.2.4	European - Loop Tests with Ports Set for Fixed Rate	PASS
ANNEX B - PHYSICAL LAYER TEST CASES FOR SYSTEMS USING G.992.1 ANNEX B		
B.2.4.1.1	Variable Rate - White Noise Impairment Only – Fast Mode	NT
B.2.4.1.2	Variable Rate - White Noise Impairment Only – Interleaved Mode	NT
B.2.4.2.1	Variable Rate - ETSI FB Impairment – Fast Mode	NT
B.2.4.2.2	Variable Rate - ETSI FB Impairment – Interleaved Mode	NT
B.2.5.1a	White Noise Impairment with Ports Set for Fixed Rate – 864/160 kbps	NT
B.2.5.1b	White Noise Impairment with Ports Set for Fixed Rate – 4096/384 kbps	NT
B.2.5.2a	ETSI FB Impairment with Ports Set for Fixed Rate – 864/160 kbps	NT
B.2.5.2b	ETSI FB Impairment with Ports Set for Fixed Rate – 2048/256 kbps	NT
B.2.5.2c	ETSI FB Impairment with Ports Set for Fixed Rate – 4096/384 kbps	NT
B.2.5.2d	ETSI FB Impairment with Ports Set for Fixed Rate – 6144/640 kbps	NT

Test Setups

Test Setup 1: Basic Test Setup

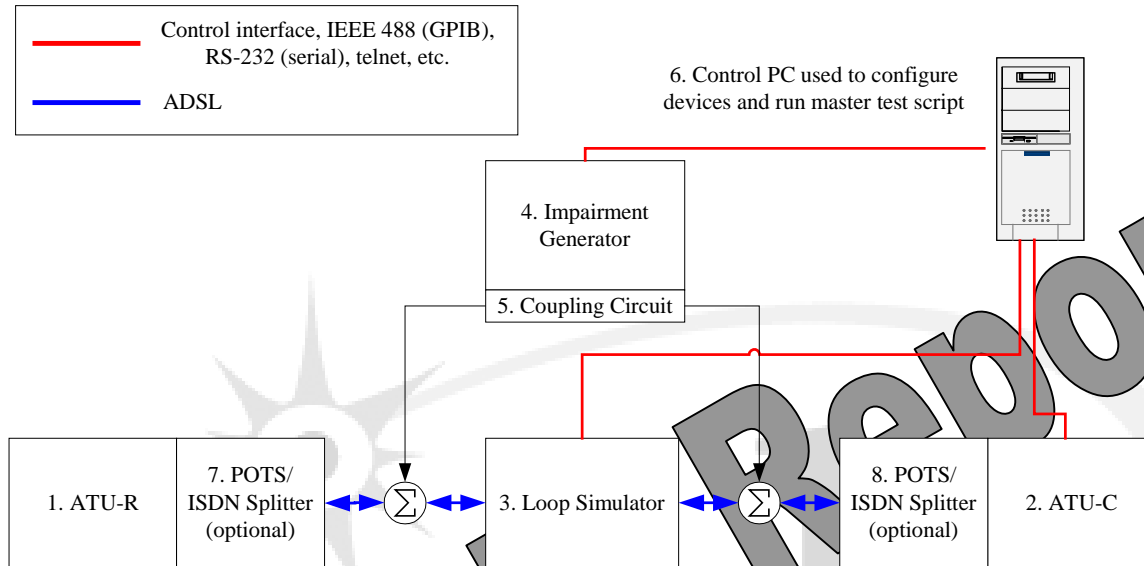

Equipment List

1. DSL Consortium Model A (IOL ID: 9999).
 - Chipset Make: DSL Consortium.
 - Chipset Model: DC1.
 - Chipset Firmware Version: 1.2.3.
 - The Model A was set to train in multimode.
2. DSL Consortium Model B
 - Line-card: DSL TU-128 (IOL ID: 9998).
 - Chipset Make: DSL Consortium.
 - Chipset Model: DCCO2.
 - Chipset Firmware Version: 3.2.1.
 - System Software Version: 3.2.
 - Target Noise Margin: 6 dB for upstream and downstream.
 - The default maximum interleave delay for the high latency path was set to 16 ms and 1 ms for the low latency path.
 - Maximum upstream data rate 800 kbps, maximum downstream data rate 8000 kbps.
 - Minimum upstream and downstream data rate 32 kbps.
 - The DSL TU-128 was set to train in multimode (ADSL/ADSL2/ADSL2+).
 - Net data rates were taken from the ATU-C serial configuration interface.
3. Loop simulator: Company X Model X1.
 - Loop simulator serial #: 001122334455.
4. Impairment generator: Company Y Model Y2.
 - White_noise_file.txt.
5. Coupling Circuit: Company Z Model Z3.
6. Testing station 6 with LASI (Lasi Automation with Standard Interfaces) version 2005.01.01.
7. Splitter Information: No CPE splitter installed.
8. Splitter Information: No CO splitter installed.
9. ATM Traffic Generator/Analyzer: Company W Model W5.

Test Number and Label		Result
8.1.5 – Modular Connector Pins		PASS
Method of Procedure	Verify that ADSL signal is connected to pins 3 and 4 of RJ-14 connector.	
Expected Result	ATU-R is connected via pins 3 and 4.	
Actual Result		

Test Number and Label		Result
8.1.6 – Ethernet Connector Pinout		PASS
Method of Procedure	Verify Ethernet connector pinout is such that a straight through cable is used between computer and modem.	
Expected Result	ATU-R Ethernet port is configured for straight through connection to the computer	
Actual Result		

Test Number and Label		Result
8.1.7 – Upstream Power Cutback		FAIL
Method of Procedure	Query the management system to obtain the upstream power.	
Expected Result	The reported value shall not exceed +2 dBm.	
Actual Result	The reported upstream power level was 2.3 dBm.	

Test Number and Label		Result
8.1.9 – Request Downstream Power Cutback		PASS
Method of Procedure	13. Configure the Line Simulator for a Null loop. 14. Apply white noise at a level of -140 dBm/Hz. 15. Provision the Maximum Noise Margin to 10 dB. 16. Provision the Maximum Downstream Data Rate to 1.472 Mb/s. 17. Provision the Maximum Upstream Data Rate to 256 kb/s. 18. Set up a bi-directional connection on a known VPI/VCI. 19. Query the management system (or DSLAM directly) for the total downstream power.	
Expected Result	The total downstream power shall be 0 dBm or less.	
Actual Result		

Test Number and Label		Result
8.2 – Sudden Application of RFI		PASS
Method of Procedure	<ol style="list-style-type: none"> 1. Randomly select an integer value, n, in the range 70-100, ensuring that the tone selected has assigned bits as described in the downstream bits per tone map. Avoid use of the pilot tone (#64 for Annex A or #96 for Annex B) or any unpopulated tones. 2. Record and report the value of n used. 3. Connect the ATU-R and ATU-C as per test configuration details. The frequency of the interfering ton shall be set to $n * 4.3125$ kHz. The power of the interfering tone shall be -110 dBm or less. 4. Activate the management port to record the downstream bits per tone map. 5. Increase the power of the interfering tone to -50 dBm. 6. Observe any downstream bit swap operation without retraining of the modems or change in the downstream net data rate. After 2 minutes, verify the payload or CRC errors have stopped. (There may be some initial errors seen when the signal is first inserted on the line.) 7. Randomly select an integer value, n, in the range 10-20 for Annex A or 40-50 for Annex B, ensuring that the tone n has assigned bits as described in the upstream bits per tone map. Avoid used of the pilot tone (#16 for Annex A) or any unpopulated tones. 8. Record and report the value of n used. 9. Connect the ATU-R and ATU-C as per test configuration details. The frequency of the interfering tone shall be set to $n * 4.3125$ kHz. The power of the interfering tone shall be -100 dBm or less. 10. Activate the management port to record the upstream bits per tone map. 11. Increase the tone power to -50 dBm. 12. Observe any upstream bit swap operation without retraining of the modems or change in the upstream net data rate. After 2 minutes verify the payload or CRC errors have stopped. (There may be some initial errors seen when the signal is first inserted on the line.) 	
Expected Result	The bit swap protocol re-deploys the allocation of bits among the sub-carriers with no retrain of the modems and the modems are error free ($BER < 1E-7$) after 2 minutes.	
Actual Result	<ul style="list-style-type: none"> • Tone #80 was used for the downstream direction. Two minutes after the injection of the interfering tone, no CRC errors were observed to have occurred. • Tone #12 was used for the upstream direction. Two minutes after the injection of the interfering tone, no CRC errors were observed to have occurred. 	

Test Number and Label		Result
8.4 – Stress Test		PASS
Method of Procedure	<ol style="list-style-type: none"> 1. Train the CPE with the DSLAM. 2. Wait for 1 minute after initialization. 3. Check reported margin and document as initial_reported_margin. 4. Increase the noise level by initial_reported_margin – 1 dB. 5. Configure the traffic generator/analyzer to provide MAC frames as a payload source for the duration of the test. The engineer will need to adjust the rate of the MAC frames to an acceptable level such that dropped frames due to LAN-based collisions or otherwise are negligible. Record these rates and the MAC frame size used for the test (suggested default 1024 bytes including FCS). 6. Run one over night BER test (8 hour minimum). 	
Expected Result	<ul style="list-style-type: none"> • The connection between the CPE shall not lose sync with the DSLAM at any time during the overnight test. Any retrain will constitute a failure for this section. • The BER shall be less than 1.5e-7 for the entire test. 	
Actual Result		

Test Number and Label		Result
8.5.1 – Analog Front End Power		PASS
Method of Procedure	<ol style="list-style-type: none"> 1. Connect Modem to test setup. 2. Configure Modem for Maximum Data Rate down/up. 3. Train modem. 4. Measure the total power generated into 100 Ohms over the signal passband defined in G.992.1 [1], averaged over a measurement period of at least 2 seconds. 	
Expected Result	Transmit Power as measured on the U-interface (line interface) falls within the limits specified in: <ul style="list-style-type: none"> • Annex A → ITU-T G.992.1 Annex A [1] • Annex B → ETSI TS 101 388 [7] resp. ITU-T G.992.1 Annex B [1] 	
Actual Result		

Test Number and Label		Result
8.5.2 – PSD Measurement		PASS
Method of Procedure	<ol style="list-style-type: none"> 1. Connect Modem to test setup. 2. Configure Modem for Maximum Data Rate down/up. 3. Train modem. 4. Measure the total power generated into 100 Ohms over the signal passband defined in G.992.1 [1], averaged over a measurement period of at least 2 seconds. 	
Expected Result	Transmit Power as measured on the U-interface (line interface) falls within the limits specified in: <ul style="list-style-type: none"> • Annex A → ITU-T G.992.1 Annex A [1] • Annex B → ETSI TS 101 388 [7] resp. ITU-T G.992.1 Annex B [1] 	
Actual Results		

Test Number and Label		Result
8.5.3 – Longitudinal Balance - LCL		PASS
Method of Procedure	1. Set up test according to figure 10 2. Activate test mode “online quiet.” 3. Measure Longitudinal Conversion Loss as specified in G.117 [6] in the frequency range: <ul style="list-style-type: none"> • Annex A: 25 kHz up to 1104 kHz • Annex B: 120 kHz up to 1104 kHz 	
Expected Result	Balance ≥ 40 dB	
Actual Results		

Test Number and Label		Result
9.1.4 – Default VPI/VCI		PASS
Method of Procedure	<ul style="list-style-type: none"> ▪ Having the ATU-R/CPE in its default configuration, cross connect a circuit in this default VPI/VCI and pass cells over the circuit. 	
Expected Result	<ul style="list-style-type: none"> ▪ Cells must be passed across the circuit using the default VPI/VCI value from the CPE General Information table. 	
Actual Results		

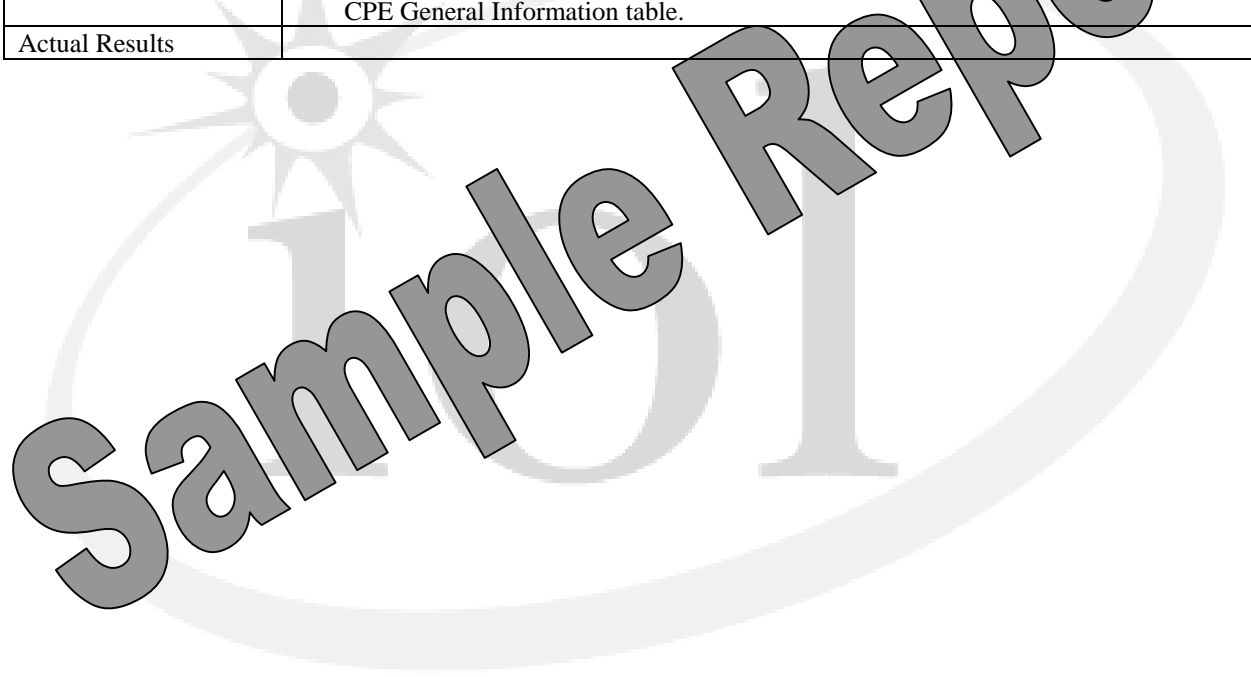

Test Number and Label		Result
9.3 - RFC 2516 [11] PPPoE End-to-End Connectivity Test		PASS
Method of Procedure	<ol style="list-style-type: none"> 1. Terminate PPPoE session between the computer and the router. 2. Verify connectivity by passing traffic over this PPPoE session. 3. Tear down the PPPoE session. 	
Expected Result	<ul style="list-style-type: none"> ▪ Transmitted packets are received. ▪ The PPPoE session has been torn down correctly. 	
Actual Results		

Test Number and Label		Result
9.4 - RFC 2364 [12] PPPoA End-to-End Connectivity Test		PASS
Method of Procedure	<ol style="list-style-type: none"> 1. Terminate PPPoA session between the computer and the broadband access server. 2. Verify connectivity by passing traffic over this PPPoA session. 3. Tear down the PPPoA session. 	
Expected Result	<ul style="list-style-type: none"> ▪ Transmitted packets are received. ▪ The PPPoA session has been torn down correctly. 	
Actual Result		

Test Number and Label		Result
9.5 - RFC 2684 [10] End-to-End Connectivity Test, applicable to Ethernet modem only		PASS
Method of Procedure	<ol style="list-style-type: none"> 1. Configure the test environment including the ATU-R and the computer so that the ATU-R/CPE Ethernet port terminates a bridge section. 2. The second termination of the bridge section should be implemented at an appropriate device within the testing environment (<i>e.g.</i>, DSLAM, PoP). 3. Pass IP packets over the complete bridge section and verify the proper reception at the destination (<i>e.g.</i>, PoP, Host PC). 	
Expected Result	Transmitted packets are received.	
Actual Results		

Test Number and Label		Result
A.1.2 - ANSI T1-413 Operation		FAIL
Method of Procedure	Query the management system to obtain operating mode.	
Expected Result	The modem shall connect in ANSI T1-413 mode in less than 60 seconds.	
Actual Results	The DUT did not connect in ANSI T1-413 mode in less than 60 seconds.	

Test Number and Label														Result		
A.1.5.1 – White Noise Impairment - Variable Rate														FAIL		
Purpose: This test is designed to measure the rate vs. reach capabilities of the DUT with –140dB AWGN impairment. Test Metric 1 through 5 must be passed. See Annex A of this document for more information.																
Results																
Loop Length (ft), 26 (AWG)	Fast Mode								Interleaved Mode							
	Upstream				Downstream				Upstream				Downstream			
	Sync Rate (kbps)			Noise Margin, Reported (dB)	Sync Rate (kbps)			Noise Margin, Reported (dB)	Sync Rate (kbps)			Noise Margin, Reported (dB)	Sync Rate (kbps)			Noise Margin, Reported (dB)
	Expected	Measured	Results		Expected	Measured	Results		Expected	Measured	Results		Expected	Measured	Results	
0	800	800	P	10	8000	8000	P	9	800	800	P	13	7616	7616	P	11
1000	800	800	P	10	8000	8000	P	9	800	800	P	13	7616	7616	P	11
2000	800	32	F	9	8000	8000	P	9	800	800	P	13	7616	7616	P	11
3000	800	800	P	10	8000	8000	P	12	800	800	P	13	7616	7616	P	14
4000	800	800	P	10	8000	8000	P	13	800	800	P	12	7616	7616	P	15
5000	800	800	P	9	8000	8000	P	11	800	800	P	13	7616	7616	P	14
6000	800	800	P	9	8000	8000	P	11	800	800	P	11	7616	7616	P	14
7000	800	800	P	8	8000	8000	P	11	800	800	P	11	7616	7616	P	14
8000	800	800	P	9	8000	8000	P	11	800	800	P	12	7616	7616	P	13
9000	800	800	P	8	7648	8000	P	9	800	96	F	9	7616	7616	P	11
10000	800	800	P	8	6464	7872	P	6	800	96	F	8	6528	7616	P	8
11000	800	32	F	10	5216	6624	F	5	800	800	P	9	5216	7104	P	6
12000	800	768	F	6	4032	5440	P	6	800	800	P	8	4064	6144	P	4
13000	768	704	F	6	3008	4256	P	7	768	800	P	6	3040	4768	P	4
14000	672	640	F	6	2240	3200	P	7	704	736	P	6	2336	3488	P	6
15000	608	544	F	6	1600	2304	P	7	640	640	P	6	1696	2912	P	4
16000	512	448	F	6	1088	1600	P	7	544	576	P	6	1216	2048	P	5
17000	416	NC	F	NC	704	NC	F	NC	448	NC	F	NC	832	NC	F	NC
17500	352	NC	F	NC	576	NC	F	NC	384	NC	F	NC	672	NC	F	NC
18000	320	NC	F	NC	448	NC	F	NC	352	NC	F	NC	512	NC	F	NC
Test Metrics																
1. Data Rate Requirement: 72 out of 80 test cases must pass.									59 test cases passed				FAIL			
2. Noise Margin Requirement: No noise margin < 4 dB.									0 noise margin < 4 dB				PASS			
3. NM Requirement: No more than 8 noise margins < 5 dB.									3 noise margin < 5 dB				PASS			
4. NM Requirement: No more than 10 down noise margin < 6 dB.									4 down noise margin < 6 dB				PASS			
5. Connectivity Requirement: All 80 test cases must connect.									3 test cases did not connect				FAIL			
Comments on Test Results																

Test Number and Label								Result
A.1.5.2 – 24 HDSL impairment - Variable Rate								FAIL
Purpose: This test is designed to measure the rate vs. reach capabilities of the DUT with 24 pair HDSL impairment. Test Metric 1 through 5 must be passed. See Annex A of this document for more information.								
Results								
Loop Length (ft), 26 (AWG)	Fast Mode							
	Upstream				Downstream			
	Sync Rate (kbps)			Noise Margin, Reported (dB)	Sync Rate (kbps)			Noise Margin, Reported (dB)
	Expected	Measured	Results		Expected	Measured	Results	
0	800	800	P	19.5	8000	8000	P	18
3000	800	800	P	15.1	8000	8000	P	14.5
6000	704	800	P	7.5	8000	8000	P	9.5
9000	448	544	P	6.3	6016	5376	F	5
12000	160	224	P	7	2016	1536	F	5.5
13000	96	128	P	6.6	1088	800	F	6
Test Metrics								
1. Data Rate Requirement: 11 out of 12 test cases must pass.					9 test cases passed			FAIL
2. Noise Margin Requirement: No noise margin < 4 dB.					0 noise margin < 4 dB			PASS
3. NM Requirement: No more than 1 noise margins < 5 dB.					0 noise margin < 5 dB			PASS
4. NM Requirement: No more than 2 down noise margin < 6 dB.					2 down noise margin < 6 dB			PASS
5. Connectivity Requirement: All 12 test cases must connect.					0 test cases did not connect			PASS
Comments on Test Results								

Test Number and Label								Result
A.1.5.3 – 24 DSL impairment - Variable Rate								FAIL
Purpose: This test is designed to measure the rate vs. reach capabilities of the DUT with 24 pair DSL impairment. Test Metric 1 through 5 must be passed. See Annex A of this document for more information.								
Results								
Loop Length (ft), 26 (AWG)	Fast Mode							
	Upstream				Downstream			
	Sync Rate (kbps)			Noise Margin, Reported (dB)	Sync Rate (kbps)			Noise Margin, Reported (dB)
	Expected	Measured	Results		Expected	Measured	Results	
0	800	1040	P	6.5	8000	23794	P	5.5
3000	800	1023	P	6	8000	22675	P	6
6000	800	1047	P	6	8000	16387	P	5.5
9000	704	880	P	6	7200	8096	P	5.5
12000	448	595	P	6.5	3136	3838	P	5.5
15000	192	304	P	6	832	1395	P	5.5
16000	96	208	P	7	416	848	P	5.5
Test Metrics								
1. Data Rate Requirement: 13 out of 14 test cases must pass.					14 test cases passed		PASS	
2. Noise Margin Requirement: No noise margin < 4 dB.					0 noise margin < 4 dB		PASS	
3. NM Requirement: No more than 1 noise margins < 5 dB.					0 noise margin < 5 dB		PASS	
4. NM Requirement: No more than 2 down noise margin < 6 dB.					6 down noise margin < 6 dB		FAIL	
5. Connectivity Requirement: All 14 test cases must connect.					0 test cases did not connect		PASS	
Comments on Test Results								

Test Number and Label								Result
A.1.5.4 – 5 T1 impairment - Variable Rate								FAIL
Purpose: This test is designed to measure the rate vs. reach capabilities of the DUT with 5 pair T1 impairment. Test Metric 1 through 5 must be passed. See Annex A of this document for more information.								
Results								
Loop Length (ft), 26 (AWG)	Fast Mode							
	Upstream				Downstream			
	Sync Rate (kbps)			Noise Margin, Reported (dB)	Sync Rate (kbps)			Noise Margin, Reported (dB)
	Expected	Measured	Results		Expected	Measured	Results	
0	800	800	P	12	8000	8000	P	11
3000	800	800	P	12.5	8000	8000	P	8.5
6000	800	800	P	11.5	5824	5824	P	9
9000	800	800	P	10.5	2336	2368	P	9
12000	800	736	F	7.5	864	928	P	8.5
15000	576	NC	F	NC	256	NC	F	NC
Test Metrics								
1. Data Rate Requirement: 11 out of 12 test cases must pass.					9 test cases passed		FAIL	
2. Noise Margin Requirement: No noise margin < 4 dB.					0 noise margin < 4 dB		PASS	
3. NM Requirement: No more than 1 noise margins < 5 dB.					0 noise margin < 5 dB		PASS	
4. NM Requirement: No more than 2 down noise margin < 6 dB.					0 down noise margin < 6 dB		PASS	
5. Connectivity Requirement: All 12 test cases must connect.					1 test cases did not connect		FAIL	
Comments on Test Results								

Test Number and Label						Result
A.1.6.1 – Loop Tests with Ports Set for Fixed Rate						PASS
Purpose: This test is designed to measure the rate vs. reach capabilities of the DUT at a fixed rate of 128.256 kbps. If any reported noise margin is less than 6 dB, then the ATU-C/ATU-R pair fails that section. 16 out of 16 test cases must be passed.						
Test Metrics and Results						
Loop Length (ft), 26 (AWG)	Fast Mode			Interleaved Mode		
	Modem Trained (Y/N)?	Upstream Noise Margin, Reported (dB)	Downstream Noise Margin, Reported (dB)	Modem Trained (Y/N)?	Upstream Noise Margin, Reported (dB)	Downstream Noise Margin, Reported (dB)
0	Y	23	31	Y	23	31
3000	Y	22	31	Y	21	31
6000	Y	21	31	Y	20	31
9000	Y	20	31	Y	20	31
12000	Y	20	27	Y	19	27
15000	Y	16	19	Y	16	19
17000	Y	11	11	Y	11	11
17500	Y	9	11	Y	9	11
Comments on Test Results						

Test Number and Label								Result
A.1.7.1 – CSA #4 Standard Loop – Variable Rate								FAIL
Purpose: This test is designed to measure the rate vs. reach capabilities of the DUT with various impairments on the CSA #4 Standard Loop. Test Metric 1 through 5 must be passed. See Annex A of this document for more information.								
Results								
Disturber Type	Fast Mode							
	Upstream				Downstream			
	Sync Rate (kbps)			Results	Sync Rate (kbps)			Results
	Expected	Measured	Noise Margin, Reported (dB)		Expected	Measured	Noise Margin, Reported (dB)	
White Noise	800	800	6	P	8000	6976	7	F
24 HDSL	512	480	8	F	6464	5600	7	F
5 T1	800	800	10	P	2208	1792	7	F
24 DSL (ISDN)	736	704	6	F	7584	6720	7	F
Test Metrics								
1. Data Rate Requirement: 7 out of 8 test cases must pass.					2 test cases passed		FAIL	
2. Noise Margin Requirement: No noise margin < 4 dB.					0 noise margin < 4 dB		PASS	
3. NM Requirement: No more than 1 noise margins < 5 dB.					0 noise margin < 5 dB		PASS	
4. NM Requirement: No more than 1 down noise margin < 6 dB.					0 down noise margin < 6 dB		PASS	
5. Connectivity Requirement: All 8 test cases must connect.					0 test cases did not connect		PASS	
Comments on Test Results								

Test Number and Label								Result
A.1.8.1 – ANSI #13 Standard Loop – Variable Rate								FAIL
Purpose: This test is designed to measure the rate vs. reach capabilities of the DUT with various impairments on the ANSI #13 Standard Loop. Test Metric 1 through 5 must be passed. See Annex A of this document for more information.								
Results								
Disturber Type	Fast Mode							
	Upstream				Downstream			
	Sync Rate (kbps)			Results	Sync Rate (kbps)			Results
	Expected	Measured	Noise Margin, Reported (dB)		Expected	Measured	Noise Margin, Reported (dB)	
White Noise	704	448	6	F	3008	3168	6	P
24 HDSL	64	64	7	P	1312	1376	6	P
5 T1	704	448	8	F	512	800	6	P
24 DSL (ISDN)	288	288	6	P	2432	2560	6	P
Test Metrics								
1. Data Rate Requirement: 7 out of 8 test cases must pass.					6 test cases passed			FAIL
2. Noise Margin Requirement: No noise margin < 4 dB.					0 noise margin < 4 dB			PASS
3. NM Requirement: No more than 1 noise margins < 5 dB.					0 noise margin < 5 dB			PASS
4. NM Requirement: No more than 1 down noise margin < 6 dB.					0 down noise margin < 6 dB			PASS
5. Connectivity Requirement: All 8 test cases must connect.					0 test cases did not connect			PASS
Comments on Test Results								

Test Number and Label								Result
A.1.9.1 – 9kft Bridged Tap Tests – Variable Rate								FAIL
Purpose: This test is designed to measure the rate vs. reach capabilities of the DUT with –140dB AWGN impairment, on a 9kft 26 AWG loop with bridged taps. Test Metric 1 through 5 must be passed. See Annex A of this document for more information.								
Results								
Tap Length (feet)	Fast Mode							
	Upstream				Downstream			
	Sync Rate (kbps)			Results	Sync Rate (kbps)			Results
	Expected	Measured	Noise Margin, Reported (dB)		Expected	Measured	Noise Margin, Reported (dB)	
150	800	800	9.5	P	7040	6336	8.5	F
250	800	800	9	P	7168	6240	9	F
350	800	800	10	P	7520	6400	9.5	F
500	800	800	10	P	7360	7328	4.5	P
Test Metrics								
1. Data Rate Requirement: 7 out of 8 test cases must pass.					5 test cases passed			FAIL
2. Noise Margin Requirement: No noise margin < 4 dB.					0 noise margin < 4 dB			PASS
3. NM Requirement: No more than 1 noise margins < 5 dB.					1 noise margin < 5 dB			PASS
4. NM Requirement: No more than 1 down noise margin < 6 dB.					0 down noise margin < 6 dB			PASS
5. Connectivity Requirement: All 8 test cases must connect.					0 test cases did not connect			PASS
Comments on Test Results								

Test Number and Label								Result
A.1.9.2 – 12kft Bridged Tap Tests – Variable Rate								FAIL
Purpose: This test is designed to measure the rate vs. reach capabilities of the DUT with –140dB AWGN impairment, on a 12kft 26 AWG loop with bridged taps. Test Metric 1 through 5 must be passed. See Annex A of this document for more information.								
Results								
Tap Length (feet)	Fast Mode							
	Upstream				Downstream			
	Sync Rate (kbps)			Results	Sync Rate (kbps)			Results
	Expected	Measured	Noise Margin, Reported (dB)		Expected	Measured	Noise Margin, Reported (dB)	
0	800	800	10.7	P	4064	2528	6.5	F
50	800	800	10.8	P	4064	2720	6.5	F
150	800	800	10.8	P	3968	2624	6.5	F
250	800	800	10.5	P	3360	2240	6.5	F
350	800	800	10	P	3584	1984	6	F
500	800	800	9.8	P	3712	1952	6.5	F
750	800	800	9.1	P	3648	1920	6	F
1000	736	800	7.7	P	3584	2144	6.5	F
1250	704	768	7.5	P	3744	2208	6	F
1500	704	768	7.1	P	3808	2368	6	F
Test Metrics								
1. Data Rate Requirement: 18 out of 20 test cases must pass.					10 test cases passed		FAIL	
2. Noise Margin Requirement: No noise margin < 4 dB.					0 noise margin < 4 dB		PASS	
3. NM Requirement: No more than 2 noise margins < 5 dB.					0 noise margin < 5 dB		PASS	
4. NM Requirement: No more than 3 down noise margin < 6 dB.					0 down noise margin < 6 dB		PASS	
5. Connectivity Requirement: All 20 test cases must connect.					0 test cases did not connect		PASS	
Comments on Test Results								

Test Number and Label								Result
A.1.9.3 – 15kft Bridged Tap Tests – Variable Rate								FAIL
Purpose: This test is designed to measure the rate vs. reach capabilities of the DUT with –140dB AWGN impairment, on a 15kft 26 AWG loop with bridged taps. Test Metric 1 through 5 must be passed. See Annex A of this document for more information.								
Results								
Tap Length (feet)	Fast Mode							
	Upstream				Downstream			
	Sync Rate (kbps)			Results	Sync Rate (kbps)			Results
	Expected	Measured	Noise Margin, Reported (dB)		Expected	Measured	Noise Margin, Reported (dB)	
0	608	352	6	F	1568	1792	6	P
50	608	352	6	F	1600	1792	6	P
150	608	352	5	F	1536	1760	6	P
200	576	352	5	F	1472	1728	6	P
300	576	352	6	F	1248	1472	6	P
400	576	320	5	F	1216	1376	4	P
500	544	320	6	F	1216	1376	6	P
600	544	288	4	F	1248	1440	6	P
700	544	256	6	F	1280	1376	6	P
800	512	256	6	F	1312	1472	6	P
900	480	224	6	F	1280	1472	6	P
1000	480	224	6	F	1248	1504	6	P
1250	416	192	5	F	1344	1632	6	P
1500	416	160	6	F	1376	1664	6	P
Test Metrics								
1. Data Rate Requirement: 25 out of 28 test cases must pass.					14 test cases passed		FAIL	
2. Noise Margin Requirement: No noise margin < 4 dB.					0 noise margin < 4 dB		PASS	
3. NM Requirement: No more than 3 noise margins < 5 dB.					2 noise margin < 5 dB		PASS	
4. NM Requirement: No more than 4 down noise margin < 6 dB.					1 down noise margin < 6 dB		PASS	
5. Connectivity Requirement: All 28 test cases must connect.					0 test cases did not connect		PASS	
Comments on Test Results								

Test Number and Label								Result
A.1.9.4 – 17.5kft Bridged Tap Tests – Variable Rate								FAIL
Purpose: This test is designed to measure the rate vs. reach capabilities of the DUT with –140dB AWGN impairment, on a 17.5kft 26 AWG loop with bridged taps. Test Metric 1 through 5 must be passed. See Annex A of this document for more information.								
Results								
Tap Length (feet)	Fast Mode							
	Upstream				Downstream			
	Sync Rate (kbps)			Results	Sync Rate (kbps)			Results
	Expected	Measured	Noise Margin, Reported (dB)		Expected	Measured	Noise Margin, Reported (dB)	
0	352	192	6	F	576	800	7	P
50	352	192	7	F	576	800	7	P
150	352	192	7	F	544	704	7	P
200	352	192	7	F	512	704	7	P
300	352	192	7	F	448	640	7	P
400	352	192	7	F	416	512	7	P
500	352	160	9	F	320	320	7	P
600	320	160	8	F	288	384	7	P
700	288	160	7	F	256	384	7	P
800	288	160	7	F	256	416	7	P
900	256	128	7	F	352	512	7	P
1000	256	128	7	F	352	480	7	P
1250	192	96	7	F	416	512	6	P
1500	192	64	8	F	448	576	7	P
Test Metrics								
1. Data Rate Requirement: 25 out of 28 test cases must pass.					14 test cases passed			FAIL
2. Noise Margin Requirement: No noise margin < 4 dB.					0 noise margin < 4 dB			PASS
3. NM Requirement: No more than 3 noise margins < 5 dB.					0 noise margin < 5 dB			PASS
4. NM Requirement: No more than 4 down noise margin < 6 dB.					0 down noise margin < 6 dB			PASS
5. Connectivity Requirement: All 28 test cases must connect.					0 test cases did not connect			PASS
Comments on Test Results								

Test Number and Label																Result
A.2.3.1 – European Loops - White Noise Impairment - Variable Rate																PASS
Purpose: This test is designed to measure the rate vs. reach capabilities of the DUT with –140dB AWGN impairment for European Loops. 40 out of 44 test cases must be passed.																
Results																
Loop Length (m, ETSI loop #1)	Fast Mode								Interleaved Mode							
	Upstream				Downstream				Upstream				Downstream			
	Sync Rate (kbps)			Noise Margin, Reported (dB)	Sync Rate (kbps)			Noise Margin, Reported (dB)	Sync Rate (kbps)			Noise Margin, Reported (dB)	Sync Rate (kbps)			Noise Margin, Reported (dB)
	Expected	Measured	Results		Expected	Measured	Results		Expected	Measured	Results		Expected	Measured	Results	
0	800	1197	P	6.3	8000	19994	P	17.8	800	1196	P	6.7	7616	19991	P	17.8
500	800	1197	P	6.3	8000	19994	P	15.2	800	1196	P	6.5	7616	19991	P	15.3
1000	800	1197	P	6.4	8000	19994	P	13.6	800	1196	P	6.7	7616	19991	P	13.6
1500	800	1197	P	6.6	8000	19994	P	6.9	800	1196	P	6.5	7616	19991	P	7.3
2000	800	1197	P	6.7	8000	16266	P	6.5	800	1196	P	6.9	7616	16963	P	6.9
2500	800	1197	P	6.1	8000	11502	P	6.1	800	1196	P	6.1	7616	12054	P	6.4
3000	800	1121	P	5.3	6144	8073	P	6	800	1153	P	5.4	6304	8599	P	6
3500	736	973	P	5.1	3968	5545	P	6.1	800	1005	P	5.3	4192	5937	P	6.1
4000	672	848	P	4.2	2592	3785	P	6.1	704	875	P	5.2	2848	4090	P	6.1
4500	544	716	P	4.3	1504	2501	P	6.1	576	740	P	5.1	1696	2776	P	6.1
5000	320	549	P	6.1	768	1505	P	6.3	352	581	P	5.9	928	1722	P	6.1
Test Metrics																
1. Data Rate Requirement: 25 out of 28 test cases must pass.									44 test cases passed						PASS	
2. Noise Margin Requirement: No noise margin < 4 dB.									0 noise margin < 4 dB						PASS	
3. NM Requirement: No more than 3 noise margins < 5 dB.									2 noise margin < 5 dB						PASS	
4. NM Requirement: No more than 4 down noise margin < 6 dB.									0 down noise margin < 6 dB						PASS	
5. Connectivity Requirement: All 28 test cases must connect.									0 test cases did not connect						PASS	
Comments on Test Results																

Test Number and Label														Result		
A.2.3.2 – European Loops – FB Impairment - Variable Rate														PASS		
Purpose: This test is designed to measure the rate vs. reach capabilities of the DUT with FB Impairment. 29 out of 32 test cases must be passed.																
Results																
Loop Length (m, ETSI loop #1)	Fast Mode								Interleaved Mode							
	Upstream				Downstream				Upstream				Downstream			
	Sync Rate (kbps)		Results	Noise Margin, Reported (dB)	Sync Rate (kbps)		Results	Noise Margin, Reported (dB)	Sync Rate (kbps)		Results	Noise Margin, Reported (dB)	Sync Rate (kbps)		Results	Noise Margin, Reported (dB)
	Expected	Measured			Expected	Measured			Expected	Measured			Expected	Measured		
0	800	884	P	6	5984	5997	P	6	800	919	P	6	6144	6456	P	6.1
500	800	877	P	6	7328	7917	P	6.1	800	908	P	6	7488	8445	P	6
1250	768	901	P	6	7296	8580	P	6	800	930	P	6	7392	9004	P	6
1500	736	893	P	6	6368	7945	P	6	768	919	P	6	6660	8453	P	5.9
1750	704	893	P	6.1	5568	7125	P	6	736	923	P	6	5984	7588	P	6
2000	640	825	P	6	4704	5993	P	6.1	672	851	P	6	5024	6507	P	6
2500	512	656	P	6	2368	3373	P	6.2	544	690	P	6	2944	3925	P	6.1
3000	384	481	P	6	544	1085	P	6.2	416	528	P	5.9	1024	1448	P	6.2
Test Metrics																
1. Data Rate Requirement: 29 out of 32 test cases must pass.										32 test cases passed				PASS		
2. Noise Margin Requirement: No noise margin < 4 dB.										0 noise margin < 4 dB				PASS		
3. NM Requirement: No more than 3 noise margins > 5 dB.										0 noise margin < 5 dB				PASS		
4. NM Requirement: No more than 4 down noise margin < 6 dB.										1 down noise margin < 6 dB				PASS		
5. Connectivity Requirement: All 32 test cases must connect.										0 test cases did not connect				PASS		
Comments on Test Results																

Test Number and Label						Result
A.2.4.1a – European Loop Tests with Ports Set for Fixed Rate – 832/192kbps						PASS
Purpose: This test is designed to measure the rate vs. reach capabilities of the DUT at a fixed rate of 832/192 kbps. 10 out of 10 test cases must be passed.						
Test Metrics and Results						
Loop Length (m, ETSI loop #1)	Fast Mode			Interleaved Mode		
	Modem Trained (Y/N)?	Upstream Noise Margin, Reported (dB)	Downstre am Noise Margin, Reported (dB)	Modem Trained (Y/N)?	Upstream Noise Margin, Reported (dB)	Downstre am Noise Margin, Reported (dB)
0	Y	31.5	32	Y	32.5	34.5
500	Y	33.5	32	Y	34.5	34.5
1000	Y	34.5	30.5	Y	35.5	33
2000	Y	26	24.5	Y	27	27.5
2900	Y	17.5	10.5	Y	18.5	13
3000	Y	16.5	8.5	Y	17.5	11
Comments on Test Results						

Test Number and Label						Result
A.2.4.1b – European Loop Tests with Ports Set for Fixed Rate – 1504/320 kbps						PASS
Purpose: This test is designed to measure the rate vs. reach capabilities of the DUT at a fixed rate of 1504/320 kbps. 10 out of 10 test cases must be passed.						
Test Metrics and Results						
Loop Length (m, ETSI loop #1)	Fast Mode			Interleaved Mode		
	Modem Trained (Y/N)?	Upstream Noise Margin, Reported (dB)	Downstre am Noise Margin, Reported (dB)	Modem Trained (Y/N)?	Upstream Noise Margin, Reported (dB)	Downstre am Noise Margin, Reported (dB)
0	Y	27.5	29	Y	27	31.5
500	Y	30	29	Y	30	31.5
1000	Y	29.5	28.5	Y	30	31
2000	Y	22	21	Y	22.5	24
2750	Y	14.5	8	Y	15	10.5
2900	Y	13	7	Y	14	9.5
Comments on Test Results						

Test Number and Label						Result
A.2.4.1c – European Loop Tests with Ports Set for Fixed Rate – 4832/640 kbps						PASS
Purpose: This test is designed to measure the rate vs. reach capabilities of the DUT at a fixed rate of 4832/640 kbps. 8 out of 8 test cases must be passed.						
Test Metrics and Results						
Loop Length (m, ETSI loop #1)	Fast Mode			Interleaved Mode		
	Modem Trained (Y/N)?	Upstream Noise Margin, Reported (dB)	Downstre am Noise Margin, Reported (dB)	Modem Trained (Y/N)?	Upstream Noise Margin, Reported (dB)	Downstre am Noise Margin, Reported (dB)
0	Y	17.5	20	Y	16.5	23
750	Y	21	22.5	Y	20	24.5
1250	Y	18	21	Y	17	23.5
1950	Y	12	12.5	Y	11	15
2100	Y	11	9.5	Y	10	12
Comments on Test Results						

Sample Report



Annex A: TR-067 Pass/Fail Criteria for Rate Adaptive Tests

Training pass/fail case: It is required that the modem trains in every loop reach test. A failure to train in any test will result in a failure of that section. This is required to eliminate the possibility of any modem with interoperability ‘holes’ from passing the requirements contained within this document. (TR-067, section 8 pg. 23)

Rate dependent pass/fail case: In rate-adaptive testing, any test point that fails to meet the requirement in the downstream direction by 96 kbps or less or in the upstream direction by 32 kbps shall be re-tested 3 times. If a re-test is performed, then the maximum downstream value achieved during testing, along with the associated upstream rate, shall be recorded. (TR-067, section 8 pg. 24)

Noise margin pass/fail case: All measurements shall be from the DSLAM. Violation of any of the requirements in the noise margin chart (Table A.1) shall constitute a test section failure. (TR-067, section A.1.5 pg. 56 – 57)
The following table outlines the pass/fail criteria.

Reported Noise Margin (dB)	Requirement
< 4	On no test point
>= 4 and < 5	On at most 10% of the test points
>= 5	On at least 90% of the test points
>= 6	On at least 75% of the downstream test points

Table A.1: Noise margin chart

Overall pass/fail criteria for each adaptive rate test section is then as follows:

- ❑ If any reported noise margin is less than 4dB, then the ATU-C/ATU-R pair fails the *noise margin* requirements of that section.
- ❑ If more than 10% of the reported noise margins are less than 5dB in a section, then the ATUC/ATU-R pair fails the *noise margin* requirements of that section.
- ❑ If more than 25% of the reported downstream noise margins are less than 6dB in a section, then the ATU-C/ATU-R pair fails the *noise margin* requirements of that section.
- ❑ If more than 10% of the data rates are less than the data rate requirements in a section, then the ATU-C/ATU-R pair fails the *data rate* requirements of that section.
- ❑ If the ATU-C/ATU-R pair passes *both the data rate and noise margin* requirements, it passes the section; otherwise, it fails the section.

The following table lists the number of test points per section corresponding to the 10% and 25% limits mentioned above.

Section Number	Number of test points in section	10 % limit	25% limit (applies to downstream margins only)
A.1.5.1	80	8	10
A.1.5.2	12	1	2
A.1.5.3	14	1	2
A.1.5.4	12	1	2
A.1.7	8	1	1
A.1.8	8	1	1
A.1.9.1	8	1	1
A.1.9.2	20	2	3
A.1.9.3	28	3	4
A.1.9.4	28	3	4

Table A.2: Reported Margin Requirements

Annex B: Raw Results for rate adaptive tests.

Test A.1.5.1, -140 dBm/Hz AWGN Impairment, Low Latency Path											
Length (ft)	0	1000	2000	3000	4000	5000	6000	7000	8000	9000	
Expected UBR	800	800	800	800	800	800	800	800	800	800	800
Expected DBR	8000	8000	8000	8000	8000	8000	8000	8000	8000	8000	7684
Iteration 1	UBR	800	800	32	800	800	800	800	800	800	800
	DBR	8000	8000	8000	8000	8000	8000	8000	8000	8000	8000
	UNM	10	10	9	10	10	9	9	8	9	8
	DNM	9	9	9	12	13	11	11	11	11	9
	Time	23	22	37	22	30	29	22	23	22	23
	Mode	DMT	DMT	DMT	DMT	DMT	DMT	DMT	DMT	DMT	DMT
Iteration 2	UBR	800	800	800	800	800	800	32	800	800	82
	DBR	8000	8000	8000	8000	8000	8000	8000	8000	8000	8000
	UNM	10	10	10	10	9	9	9	9	8	8
	DNM	9	9	9	12	13	13	12	11	11	9
	Time	58	22	22	23	23	22	37	23	23	36
	Mode	DMT	DMT	DMT	DMT	DMT	DMT	DMT	DMT	DMT	DMT
Iteration 3	UBR	800	32	800	SF	800	800	800	800	800	800
	DBR	8000	8000	8000	SF	8000	8000	8000	8000	8000	8000
	UNM	10	9	10	SF	10	9	9	9	8	8
	DNM	9	9	9	SF	13	12	12	11	11	9
	Time	22	37	23	SF	22	22	25	22	22	23
	Mode	DMT	DMT	DMT	SF	DMT	DMT	DMT	DMT	DMT	DMT
Iteration 4	UBR	800	800	800	NC	800	800	800	800	800	800
	DBR	8000	8000	8000	NC	8000	8000	8000	8000	8000	8000
	UNM	10	10	11	NC	9	10	9	8	8	8
	DNM	9	9	9	NC	13	12	12	11	11	9
	Time	59	32	23	NC	22	22	23	22	24	22
	Mode	DMT	DMT	DMT	NC	DMT	DMT	DMT	DMT	DMT	DMT
Length (ft)	10000	11000	12000	13000	14000	15000	16000	17000	17500	18000	
Expected UBR	800	800	800	768	672	608	512	416	352	320	
Expected DBR	6464	5216	4032	3008	2240	1600	1088	704	576	448	
Iteration 1	UBR	800	32	768	704	640	544	448	NC	NC	NC
	DBR	7872	6624	5376	4256	3168	2304	1600	NC	NC	NC
	UNM	8	10	6	6	6	6	6	NC	NC	NC
	DNM	6	5	7	7	7	7	7	NC	NC	NC
	Time	51	37	29	31	22	22	41	NC	NC	NC
	Mode	DMT	DMT	DMT	DMT	DMT	DMT	DMT	NC	NC	NC
Iteration 2	UBR	NC	800	768	704	640	544	480	NC	NC	NC
	DBR	NC	6560	5376	4256	3168	2304	1600	NC	NC	NC
	UNM	NC	7	6	6	6	6	6	NC	NC	NC
	DNM	NC	7	7	6	7	7	7	NC	NC	NC
	Time	NC	22	23	30	23	37	23	NC	NC	NC
	Mode	NC	DMT	DMT	DMT	DMT	DMT	DMT	NC	NC	NC
Iteration 3	UBR	800	800	768	704	640	544	448	NC	NC	NC
	DBR	7840	6624	5440	4224	3168	2272	1600	NC	NC	NC
	UNM	7	7	6	6	6	6	6	NC	NC	NC
	DNM	7	7	6	7	7	7	7	NC	NC	NC
	Time	52	22	30	25	23	30	55	NC	NC	NC
	Mode	DMT	DMT	DMT	DMT	DMT	DMT	DMT	NC	NC	NC
Iteration 4	UBR	800	32	736	704	640	544	448	NC	NC	NC
	DBR	7776	6656	5344	4256	3200	2336	1600	NC	NC	NC
	UNM	7	9	7	5	6	6	6	NC	NC	NC
	DNM	7	4	7	6	7	7	7	NC	NC	NC
	Time	51	44	23	24	23	22	31	NC	NC	NC
	Mode	DMT	DMT	DMT	DMT	DMT	DMT	DMT	NC	NC	NC

DSL Forum TR-067
DSL Consortium Model A (IOL ID: 9999)

Test A.1.5.1, -140 dBm/Hz AWGN Impairment, High Latency Path												
Length (ft)	0	1000	2000	3000	4000	5000	6000	7000	8000	9000		
Expected UBR	800	800	800	800	800	800	800	800	800	800	800	
Expected DBR	7616	7616	7616	7616	7616	7616	7616	7616	7616	7616	7616	
Iteration 1	UBR	800	800	800	800	800	800	800	800	800	96	
	DBR	7616	7616	7616	7616	7616	7616	7616	7616	7616	7616	
	UNM	13	13	13	13	12	13	11	11	12	9	
	DNM	11	11	11	14	15	14	14	14	14	13	11
	Time	22	22	22	23	23	23	22	22	22	23	36
	Mode	DMT	DMT	DMT	DMT	DMT	DMT	DMT	DMT	DMT	DMT	DMT
Iteration 2	UBR	800	800	800	800	NC	96	800	96	800	800	
	DBR	7616	7616	7616	7616	NC	7616	7616	7616	7616	7616	
	UNM	13	13	13	13	NC	8	12	8	11	10	
	DNM	12	11	11	13	NC	14	14	14	13	11	
	Time	32	30	23	23	NC	37	22	36	23	23	
	Mode	DMT	DMT	DMT	DMT	NC	DMT	DMT	DMT	DMT	DMT	DMT
Iteration 3	UBR	NC	800	800	800	800	800	800	800	800	800	
	DBR	NC	7616	7616	7616	7616	7616	7616	7616	7616	7616	
	UNM	NC	13	13	13	12	12	12	11	12	11	
	DNM	NC	11	11	14	15	14	14	14	13	11	
	Time	NC	23	32	22	60	23	22	22	22	46	
	Mode	NC	DMT	DMT	DMT	DMT	DMT	DMT	DMT	DMT	DMT	DMT
Iteration 4	UBR	96	800	800	800	96	96	800	800	800	800	
	DBR	7616	7616	7616	7616	7616	7616	7616	7616	7616	7616	
	UNM	8	13	13	13	8	8	12	11	12	11	
	DNM	11	11	11	14	16	14	14	14	13	11	
	Time	42	22	22	23	36	37	60	23	23	24	
	Mode	DMT	DMT	DMT	DMT	DMT	DMT	DMT	DMT	DMT	DMT	DMT
Length (ft)	10000	11000	12000	13000	14000	15000	16000	17000	17500	18000		
Expected UBR	800	800	800	768	704	640	544	448	384	352		
Expected DBR	6528	5216	4064	3040	2336	1696	1216	832	672	512		
Iteration 1	UBR	96	800	800	800	736	640	576	NC	NC	NC	
	DBR	7616	7104	6144	4768	3488	2912	2048	NC	NC	NC	
	UNM	8	9	8	6	6	6	6	NC	NC	NC	
	DNM	8	6	4	4	6	4	5	NC	NC	NC	
	Time	27	37	29	23	22	30	37	NC	NC	NC	
	Mode	DMT	DMT	DMT	DMT	DMT	DMT	DMT	NC	NC	NC	
Iteration 2	UBR	800	800	800	800	736	96	544	NC	NC	NC	
	DBR	7616	7104	6176	4768	3520	2912	2080	NC	NC	NC	
	UNM	11	9	8	6	6	9	6	NC	NC	NC	
	DNM	8	6	4	5	5	5	4	NC	NC	NC	
	Time	30	23	23	35	29	45	34	NC	NC	NC	
	Mode	DMT	DMT	DMT	DMT	DMT	DMT	DMT	NC	NC	NC	
Iteration 3	UBR	800	800	800	800	736	640	544	NC	NC	NC	
	DBR	7616	7104	6176	4800	3520	2912	2048	NC	NC	NC	
	UNM	11	9	8	6	6	6	6	NC	NC	NC	
	DNM	8	6	4	5	6	4	5	NC	NC	NC	
	Time	23	23	23	23	22	29	28	NC	NC	NC	
	Mode	DMT	DMT	DMT	DMT	DMT	DMT	DMT	NC	NC	NC	
Iteration 4	UBR	800	800	800	800	704	NC	544	NC	NC	NC	
	DBR	7616	7104	6112	4768	3488	NC	1888	NC	NC	NC	
	UNM	10	10	9	5	6	NC	6	NC	NC	NC	
	DNM	8	6	4	5	6	NC	6	NC	NC	NC	
	Time	23	22	33	22	22	NC	40	NC	NC	NC	
	Mode	DMT	DMT	DMT	DMT	DMT	NC	DMT	NC	NC	NC	

Test A.1.5.2, 24 HDSL Impairment, Low Latency Path							
Length (ft)	0	3000	6000	9000	12000	13000	
Expected UBR	800	800	704	448	160	96	
Expected DBR	8000	8000	8000	6016	2016	1088	
Iteration 1	UBR	800	800	800	544	224	128
	DBR	8000	8000	8000	5376	1536	800
	UNM	19.5	15.1	7.5	6.3	7	6.6
	DNM	18	14.5	9.5	5	5.5	6
	Time	12	18	12	12	12	12
	Mode	DMT	DMT	DMT	DMT	DMT	DMT
Iteration 2	UBR	800	800	800	544	256	128
	DBR	8000	8000	8000	5280	1536	800
	UNM	20	15.1	7.5	6.2	6	6.6
	DNM	16.5	14	9.5	5	5.5	6
	Time	18	12	12	12	12	12
	Mode	DMT	DMT	DMT	DMT	DMT	DMT
Iteration 3	UBR	800	800	800	544	256	128
	DBR	8000	8000	8000	5376	1664	800
	UNM	19.8	15.3	7.3	6.2	5.8	6.8
	DNM	18	16.5	10.5	5	5	6
	Time	12	12	12	12	12	12
	Mode	DMT	DMT	DMT	DMT	DMT	DMT
Iteration 4	UBR	800	800	800	544	256	128
	DBR	8000	8000	8000	5376	1536	768
	UNM	19.8	15.3	7.2	6.2	5.8	6.8
	DNM	18	16	9.5	5	5.5	6
	Time	12	12	12	18	12	12
	Mode	DMT	DMT	DMT	DMT	DMT	DMT

Test A.1.5.3, 24 DSL Impairment, Low Latency Path								
Length (ft)	0	3000	6000	9000	12000	15000	16000	
Expected UBR	800	800	800	704	448	192	96	
Expected DBR	8000	8000	8000	7200	3136	832	416	
Iteration 1	UBR	1040	1023	1047	880	595	304	208
	DBR	23794	22675	16387	8096	3838	1395	848
	UNM	6.5	6	6	6	6.5	6	7
	DNM	5.5	6	5.5	5.5	5.5	5.5	5.5
	Time	41	36	42	65	65	60	65
	Mode	A2+	A2+	A2+	A2+	A2+	A2+	A2+
Iteration 2	UBR	1035	1019	1040	883	607	311	207
	DBR	23658	22675	16383	8096	3870	1407	839
	UNM	6	6.5	6	6	6	6	7
	DNM	5.5	6	5.5	5.5	5.5	5.5	5.5
	Time	42	42	42	59	59	64	64
	Mode	A2+	A2+	A2+	A2+	A2+	A2+	A2+
Iteration 3	UBR	1040	1027	1051	880	603	304	NC
	DBR	23502	22723	16343	8163	3862	1407	NC
	UNM	6	6.5	6.5	6.5	6.5	6	NC
	DNM	5.5	6	5.5	5.5	5.5	5.5	NC
	Time	41	41	42	65	59	65	NC
	Mode	A2+	A2+	A2+	A2+	A2+	A2+	NC
Iteration 4	UBR	1031	1031	1047	875	603	298	208
	DBR	23670	22595	16423	8179	3850	1399	835
	UNM	7	6	6	6	6.5	6.5	6.5
	DNM	5.5	6	6	5.5	5.5	5.5	5.5
	Time	41	41	41	41	64	65	65
	Mode	A2+	A2+	A2+	A2+	A2+	A2+	A2+

Test A.1.5.4, 5 T1 Impairment, Low Latency Path							
Length (ft)	0	3000	6000	9000	12000	15000	
Expected UBR	800	800	800	800	800	576	
Expected DBR	8000	8000	5824	2336	864	256	
Iteration 1	UBR	800	800	800	800	736	NC
	DBR	8000	8000	5728	2368	928	NC
	UNM	12	12.5	12.5	10.5	7.5	NC
	DNM	11	8.5	9.5	9	8.5	NC
	Time	19	19	19	18	21	NC
	Mode	DMT	DMT	DMT	DMT	DMT	NC
Iteration 2	UBR	800	800	800	800	736	NC
	DBR	8000	8000	5728	2368	960	NC
	UNM	12.5	12.5	12.5	11	7.5	NC
	DNM	11.5	8.5	9.5	9	8	NC
	Time	18	19	20	22	19	NC
	Mode	DMT	DMT	DMT	DMT	DMT	NC
Iteration 3	UBR	800	800	800	800	736	NC
	DBR	8000	8000	5792	2368	928	NC
	UNM	12.5	12.5	12.5	9.5	8	NC
	DNM	11.5	8.5	9	9	8.5	NC
	Time	19	18	21	19	20	NC
	Mode	DMT	DMT	DMT	DMT	DMT	NC
Iteration 4	UBR	800	800	800	800	736	NC
	DBR	8000	8000	5824	2368	992	NC
	UNM	12.5	12.5	11.5	10.5	8	NC
	DNM	11	8.5	9	9	8.5	NC
	Time	20	18	19	19	43	NC
	Mode	DMT	DMT	DMT	DMT	DMT	NC

Test A.1.7, CSA #4 Standard Loop, Low Latency Path					
	Impairment	White Noise	24 HDSL	24 DSL	5 T1
	Expected UBR	800	512	736	800
	Expected DBR	8000	6464	7584	2208
Iteration 1	UBR	800	480	800	704
	DBR	6976	5600	1792	6720
	UNM	6	8	10	6
	DNM	7	7	7	7
	Time	19	10	11	10
	Mode	DMT	DMT	DMT	DMT
Iteration 2	UBR	800	512	800	704
	DBR	6976	5536	1792	6720
	UNM	6	7	9	5
	DNM	7	7	7	7
	Time	10	10	11	30
	Mode	DMT	DMT	DMT	DMT
Iteration 3	UBR	800	480	800	704
	DBR	6912	5536	1792	6688
	UNM	5	8	10	6
	DNM	7	7	7	7
	Time	16	10	10	11
	Mode	DMT	DMT	DMT	DMT
Iteration 4	UBR	800	480	800	704
	DBR	6944	5536	1792	6720
	UNM	6	8	7	6
	DNM	7	7	7	7
	Time	10	10	10	25
	Mode	DMT	DMT	DMT	DMT

Test A.1.8, ANSI #13 Standard Loop, Low Latency Path					
Impairment	White Noise	24 HDSL	24 DSL	5 T1	
Expected UBR	704	64	288	704	
Expected DBR	3008	1312	2432	512	
Iteration 1	UBR	448	64	448	288
	DBR	3168	1376	800	2560
	UNM	6	7	8	6
	DNM	6	6	6	6
	Time	25	22	23	24
	Mode	DMT	DMT	DMT	DMT
Iteration 2	UBR	448	64	448	288
	DBR	3168	1376	800	2560
	UNM	6	7	7	5
	DNM	6	6	6	6
	Time	26	22	21	25
	Mode	DMT	DMT	DMT	DMT
Iteration 3	UBR	448	64	448	288
	DBR	3168	1344	800	2560
	UNM	5	8	7	6
	DNM	6	6	6	6
	Time	22	23	21	23
	Mode	DMT	DMT	DMT	DMT
Iteration 4	UBR	448	64	448	288
	DBR	3168	1376	800	2592
	UNM	6	8	7	6
	DNM	6	6	6	6
	Time	27	23	22	22
	Mode	DMT	DMT	DMT	DMT

Test A.1.9.1, 9 kft Bridge Tap, Low Latency Path					
Tap Length (ft)	150	250	350	500	
Expected UBR	800	800	800	800	
Expected DBR	7040	7168	7520	7360	
Iteration 1	UBR	800	800	800	800
	DBR	6336	6304	6336	5952
	UNM	10	9	10	9.5
	DNM	9	9.5	9.5	9.5
	Time	19	18	21	21
	Mode	DMT	DMT	DMT	DMT
Iteration 2	UBR	800	800	800	800
	DBR	6336	6240	6336	7328
	UNM	9.5	9	10	10
	DNM	8.5	9	9.5	4.5
	Time	20	19	19	19
	Mode	DMT	DMT	DMT	DMT
Iteration 3	UBR	800	800	800	800
	DBR	6336	6176	6304	5984
	UNM	9	9	9.5	9
	DNM	8.5	9.5	9.5	9.5
	Time	18	20	20	19
	Mode	DMT	DMT	DMT	DMT
Iteration 4	UBR	800	800	800	800
	DBR	6304	6144	6400	6080
	UNM	9.5	10	10	9.5
	DNM	9.5	9.5	9.5	9
	Time	20	18	18	19
	Mode	DMT	DMT	DMT	DMT

Test A.1.9.2, 12 kft Bridge Tap, Low Latency Path											
Tap Length (ft)	0	50	150	250	350	500	750	1000	1250	1500	
Expected UBR	800	800	800	800	800	800	800	736	704	704	
Expected DBR	4064	4064	3968	3360	3584	3712	3648	3584	3744	3808	
Iteration 1	UBR	800	800	800	800	800	800	800	800	768	768
	DBR	2528	2720	2624	2240	1984	1952	1920	2144	2208	2368
	UNM	10.7	10.8	10.8	10.5	10	9.8	9.1	7.7	7.5	7.1
	DNM	6.5	6.5	6.5	6.5	6	6.5	6	6.5	6	6
	Time	12	12	12	18	18	12	24	18	12	12
	Mode	DMT	DMT	DMT	DMT	DMT	DMT	DMT	DMT	DMT	DMT
Iteration 2	UBR	800	800	800	800	800	800	800	800	768	768
	DBR	2592	2752	2656	2240	1952	1920	1920	2176	2240	2336
	UNM	11	11	10.8	10.7	10	10	9	7.8	7.5	7.1
	DNM	6.5	6	6	6.5	6.5	6.5	6	6	6	5.5
	Time	12	12	12	12	12	12	12	18	18	12
	Mode	DMT	DMT	DMT	DMT	DMT	DMT	DMT	DMT	DMT	DMT
Iteration 3	UBR	800	800	800	800	800	800	800	800	768	768
	DBR	2592	2752	2624	2240	1984	1920	1920	2144	2208	2368
	UNM	11	11	10.7	10.6	10	10	9.1	7.7	7.5	7.1
	DNM	6.5	6	6	6.5	6	6	6	6.5	6.5	6
	Time	12	12	12	12	12	12	12	12	12	12
	Mode	DMT	DMT	DMT	DMT	DMT	DMT	DMT	DMT	DMT	DMT
Iteration 4	UBR	800	800	800	800	800	800	800	800	768	768
	DBR	2592	2720	2656	2272	1984	1920	1920	2144	2176	2368
	UNM	10.7	11.1	10.8	10.6	10.1	10	9	7.6	7.5	7.1
	DNM	6.5	6.5	6	6	6	6.5	6	6	6.5	6
	Time	12	12	12	12	12	12	18	12	12	18
	Mode	DMT	DMT	DMT	DMT	DMT	DMT	DMT	DMT	DMT	DMT

DSL Forum TR-067
DSL Consortium Model A (IOL ID: 9999)

Test A.1.9.3, 15 kft Bridge Tap, Low Latency Path							
Tap Length (ft)	0	50	150	200	300	400	500
Expected UBR	608	608	608	576	576	576	544
Expected DBR	1568	1600	1536	1472	1248	1216	1216
Iteration 1	UBR	352	352	352	352	352	320
	DBR	1792	1792	1760	1728	1472	1376
	UNM	6	6	5	5	6	5
	DNM	6	6	6	6	6	4
	Time	24	23	28	24	25	29
	Mode	DMT	DMT	DMT	DMT	DMT	DMT
Iteration 2	UBR	352	352	352	352	320	320
	DBR	1792	1792	1760	1696	1472	1376
	UNM	6	6	5	5	7	6
	DNM	6	6	6	6	6	6
	Time	23	24	23	23	23	24
	Mode	DMT	DMT	DMT	DMT	DMT	DMT
Iteration 3	UBR	352	352	352	352	320	320
	DBR	1792	1792	1760	1696	1504	1344
	UNM	6	6	5	5	6	5
	DNM	6	6	6	6	6	6
	Time	24	23	25	24	24	23
	Mode	DMT	DMT	DMT	DMT	DMT	DMT
Iteration 4	UBR	352	352	320	352	320	320
	DBR	1792	1792	1760	1696	1472	1344
	UNM	6	5	6	5	6	5
	DNM	6	6	6	6	6	6
	Time	23	23	26	23	27	22
	Mode	DMT	DMT	DMT	DMT	DMT	DMT
Tap Length (ft)	600	700	800	900	1000	1250	1500
Expected UBR	544	544	512	480	480	416	416
Expected DBR	1248	1280	1312	1280	1248	1344	1376
Iteration 1	UBR	288	256	256	224	224	192
	DBR	1440	1376	1472	1472	1504	1632
	UNM	4	6	6	6	6	5
	DNM	6	6	6	6	6	6
	Time	24	23	24	23	27	24
	Mode	DMT	DMT	DMT	DMT	DMT	DMT
Iteration 2	UBR	288	256	256	224	224	192
	DBR	1440	1408	1440	1472	1504	1632
	UNM	5	4	6	7	5	5
	DNM	6	6	6	6	6	6
	Time	23	27	29	27	33	25
	Mode	DMT	DMT	DMT	DMT	DMT	DMT
Iteration 3	UBR	288	256	256	256	224	192
	DBR	1440	1408	1472	1472	1472	1632
	UNM	5	6	6	5	5	5
	DNM	6	6	6	6	6	6
	Time	25	24	23	24	23	26
	Mode	DMT	DMT	DMT	DMT	DMT	DMT
Iteration 4	UBR	288	256	256	224	224	192
	DBR	1440	1376	1440	1472	1504	1632
	UNM	5	4	5	6	6	5
	DNM	6	4	6	6	6	6
	Time	28	29	42	27	28	25
	Mode	DMT	DMT	DMT	DMT	DMT	DMT

DSL Forum TR-067
DSL Consortium Model A (IOL ID: 9999)

Test A.1.9.4, 17.5 kft Bridge Tap, Low Latency Path							
Tap Length (ft)	0	50	150	200	300	400	500
Expected UBR	352	352	352	352	352	352	352
Expected DBR	576	576	544	512	448	416	320
Iteration 1	UBR	192	192	192	192	192	160
	DBR	800	800	704	704	640	320
	UNM	6	7	7	7	7	9
	DNM	7	7	7	7	7	7
	Time	20	18	18	18	18	20
	Mode	DMT	DMT	DMT	DMT	DMT	DMT
Iteration 2	UBR	192	192	192	192	192	160
	DBR	800	800	736	672	640	320
	UNM	7	8	7	7	7	5
	DNM	6	6	7	7	7	7
	Time	20	18	18	18	18	20
	Mode	DMT	DMT	DMT	DMT	DMT	DMT
Iteration 3	UBR	192	192	192	192	192	192
	DBR	800	768	736	704	640	352
	UNM	7	7	7	7	7	6
	DNM	7	7	7	7	7	7
	Time	20	20	18	18	18	18
	Mode	DMT	DMT	DMT	DMT	DMT	DMT
Iteration 4	UBR	192	192	192	160	192	160
	DBR	768	800	736	672	640	320
	UNM	8	6	6	7	7	7
	DNM	7	7	7	7	7	7
	Time	18	18	18	18	18	18
	Mode	DMT	DMT	DMT	DMT	DMT	DMT
Tap Length (ft)	600	700	800	900	1000	1250	1500
Expected UBR	320	288	288	256	256	192	192
Expected DBR	288	256	256	352	352	416	448
Iteration 1	UBR	160	160	160	128	128	96
	DBR	384	384	416	512	480	512
	UNM	8	7	7	7	7	7
	DNM	7	7	7	7	7	6
	Time	18	20	18	18	28	18
	Mode	DMT	DMT	DMT	DMT	DMT	DMT
Iteration 2	UBR	160	160	160	160	128	96
	DBR	384	320	416	480	480	576
	UNM	8	7	7	7	8	7
	DNM	7	8	7	7	7	7
	Time	28	32	18	20	28	18
	Mode	DMT	DMT	DMT	DMT	DMT	DMT
Iteration 3	UBR	160	160	160	128	128	96
	DBR	384	320	448	512	480	512
	UNM	7	6	6	7	7	7
	DNM	7	8	7	7	7	7
	Time	18	20	18	18	50	20
	Mode	DMT	DMT	DMT	DMT	DMT	DMT
Iteration 4	UBR	160	160	128	160	128	96
	DBR	384	416	448	512	480	576
	UNM	7	7	8	7	7	8
	DNM	7	7	7	7	7	7
	Time	20	20	18	18	28	18
	Mode	DMT	DMT	DMT	DMT	DMT	DMT

Test A.2.3.1, -140 dBm/Hz AWGN Impairment, Low Latency Path												
Length (m)	0	500	1000	1500	2000	2500	3000	3500	4000	4500	5000	
Expected UBR	800	800	800	800	800	800	800	736	672	544	320	
Expected DBR	8000	8000	8000	8000	8000	8000	6144	3968	2592	1504	768	
Iteration 1	UBR	1197	1197	1197	1197	1197	1197	1121	973	848	716	549
	DBR	19994	19994	19994	19994	16266	11502	8073	5545	3785	2501	1505
	UNM	6.3	6.3	6.4	6.6	6.7	6.1	5.3	5.1	4.2	4.3	6.1
	DNM	17.8	15.2	13.6	6.9	6.5	6.1	6	6.1	6.1	6.1	6.3
	Time	22	22	23	24	47	45	47	45	46	45	25
	Mode	A2+	A2+	A2+	A2+	A2+	A2+	A2+	A2+	A2+	A2+	A2+
Iteration 2	UBR	1197	1197	1197	1197	1197	1197	1125	973	848	713	545
	DBR	19994	19994	19994	19994	16262	11510	8037	5541	3757	2485	1501
	UNM	6.3	6.2	6.5	6.4	6.7	6.1	5.2	5.1	4.3	4.1	5.8
	DNM	17.9	15.1	13.7	7	6.5	6.1	6.1	6.1	6.2	6.1	6.2
	Time	24	22	22	22	44	47	45	45	45	45	24
	Mode	A2+	A2+	A2+	A2+	A2+	A2+	A2+	A2+	A2+	A2+	A2+
Iteration 3	UBR	1197	1197	1197	1197	1197	1197	1121	980	845	716	545
	DBR	19994	19994	19994	19994	16270	11518	8061	5529	3777	2489	1497
	UNM	6.7	6.5	6.5	6.1	6.8	6.1	5.2	4.8	4.6	4.2	6.2
	DNM	17.8	15.2	13.6	7	6.5	6.1	6	6.1	6.1	6.1	6.2
	Time	21	22	21	22	45	48	45	44	45	45	24
	Mode	A2+	A2+	A2+	A2+	A2+	A2+	A2+	A2+	A2+	A2+	A2+
Iteration 4	UBR	1197	1197	1197	1197	1197	1197	1133	977	845	713	549
	DBR	19994	19994	19994	19994	16246	11522	8077	5517	3769	2481	1497
	UNM	6.6	6.4	6.3	6.2	6.8	6.2	4.9	4.9	4.1	4.3	6.1
	DNM	17.8	15.1	13.7	7	6.5	6.1	6	6.1	6.2	6.2	6.3
	Time	22	24	22	22	45	45	45	45	44	45	26
	Mode	A2+	A2+	A2+	A2+	A2+	A2+	A2+	A2+	A2+	A2+	A2+
Test A.2.3.1, -140 dBm/Hz AWGN Impairment, High Latency Path												
Length (m)	0	500	1000	1500	2000	2500	3000	3500	4000	4500	5000	
Expected UBR	800	800	800	800	800	800	800	800	704	576	352	
Expected DBR	7616	7616	7616	7616	7616	7616	6304	4192	2848	1696	928	
Iteration 1	UBR	1196	1196	1196	1196	1196	1196	1153	1005	875	740	581
	DBR	19991	19991	19991	19991	16963	12054	8599	5937	4090	2776	1722
	UNM	6.7	6.5	6.7	6.5	6.9	6.1	5.4	5.3	5.2	5.1	5.9
	DNM	17.8	15.3	13.6	7.3	6.9	6.4	6	6.1	6.1	6.1	6.1
	Time	24	24	22	23	45	46	45	45	45	44	24
	Mode	A2+	A2+	A2+	A2+	A2+	A2+	A2+	A2+	A2+	A2+	A2+
Iteration 2	UBR	1196	1196	1196	1196	1196	1196	1157	1001	875	743	581
	DBR	19991	19991	19991	19991	16952	12042	8579	5933	4090	2764	1706
	UNM	6.6	6.3	6.2	6.7	6.2	6.2	5.3	5.3	4.9	5.1	6.1
	DNM	18.4	15.1	13.7	7.3	6.9	6.4	6	6.1	6.1	6.1	6.2
	Time	23	23	24	21	45	45	45	46	45	45	25
	Mode	A2+	A2+	A2+	A2+	A2+	A2+	A2+	A2+	A2+	A2+	A2+
Iteration 3	UBR	1196	1196	1196	1196	1196	1196	1145	1009	871	743	585
	DBR	19991	19991	19991	19991	16999	12058	8583	5933	4117	2768	1710
	UNM	6.2	6.5	6	6.5	6.8	6.1	5.4	5.1	5.3	4.9	6.1
	DNM	18.3	15.2	13.5	7.2	6.8	6.3	6	6.1	6	6.1	6.2
	Time	23	22	22	22	45	45	46	45	45	45	24
	Mode	A2+	A2+	A2+	A2+	A2+	A2+	A2+	A2+	A2+	A2+	A2+
Iteration 4	UBR	1196	1196	1196	1196	1196	1196	1149	1009	875	743	581
	DBR	19991	19991	19991	19991	16987	12081	8591	5945	4105	2772	1710
	UNM	6.3	6	6.1	6.6	6.2	6	5.2	5.2	5	5.1	6.1
	DNM	18.4	15	13.6	7.3	6.9	6.4	6	6.1	6.1	6.1	6.2
	Time	22	24	22	22	44	47	45	46	46	45	24
	Mode	A2+	A2+	A2+	A2+	A2+	A2+	A2+	A2+	A2+	A2+	A2+

Test A.2.3.2, ETSI FB Impairment, Low Latency Path									
Length (m)	0	500	1250	1500	1750	2000	2500	3000	
Expected UBR	800	800	768	736	704	640	512	384	
Expected DBR	5984	7328	7296	6368	5568	4704	2368	544	
Iteration 1	UBR	893	877	901	893	893	825	656	481
	DBR	5977	7917	8580	7945	7125	5993	3373	1085
	UNM	5.9	6	6	6	6.1	6	6	6
	DNM	6.1	6.1	6	6	6	6.1	6.2	6.2
	Time	22	23	21	21	22	22	22	43
	Mode	A2	A2	A2	A2	A2	A2	A2	A2
Iteration 2	UBR	893	877	905	897	897	820	660	484
	DBR	5989	7933	8592	7941	7109	5981	3361	1077
	UNM	6.1	6	6	6	6.1	6.1	6	6
	DNM	6.1	6	5.9	6	6	6.1	6.2	6.2
	Time	24	22	22	21	21	21	21	44
	Mode	A2	A2	A2	A2	A2	A2	A2	A2
Iteration 3	UBR	884	880	905	889	893	820	656	481
	DBR	5997	7921	8580	7953	7109	5981	3345	1093
	UNM	6	6.1	6	6.1	6	6.1	6	6
	DNM	6	6.1	6	6	6	6.1	6.2	6.2
	Time	22	22	23	22	22	22	21	44
	Mode	A2	A2	A2	A2	A2	A2	A2	A2
Iteration 4	UBR	889	877	905	897	901	825	656	481
	DBR	5981	7933	8588	7945	7109	5973	3361	1105
	UNM	6	6	6.1	6	6	6	6.1	6.1
	DNM	6.1	6	5.9	6.1	6	6.1	6.2	6.2
	Time	22	21	23	21	21	22	21	44
	Mode	A2	A2	A2	A2	A2	A2	A2	A2
Test A.2.3.2, ETSI FB Impairment, High Latency Path									
Length (m)	0	500	1250	1500	1750	2000	2500	3000	
Expected UBR	800	800	768	736	704	640	512	384	
Expected DBR	5984	7328	7296	6368	5568	4704	2368	544	
Iteration 1	UBR	919	908	930	919	923	851	690	528
	DBR	6456	8445	9004	8453	7588	6507	3925	1448
	UNM	6	6	6	6	6	6	6	5.9
	DNM	6.1	6	6	5.9	6	6	6.1	6.2
	Time	23	23	23	24	21	21	21	44
	Mode	A2	A2	A2	A2	A2	A2	A2	A2
Iteration 2	UBR	919	911	934	923	923	851	694	528
	DBR	6499	8434	9038	8434	7557	6503	3929	1472
	UNM	6	6	6	6	6.1	6	6.1	6
	DNM	6	6	5.9	5.9	6.1	6	6.1	6.2
	Time	22	22	22	22	22	21	21	44
	Mode	A2	A2	A2	A2	A2	A2	A2	A2
Iteration 3	UBR	915	911	930	919	923	851	690	528
	DBR	6495	8442	9042	8430	7580	6511	3913	1472
	UNM	6.1	6	6.1	6	6	6	6	5.9
	DNM	6	6	5.9	6	6	6	6.2	6.2
	Time	22	42	21	23	21	22	21	44
	Mode	A2	A2	A2	A2	A2	A2	A2	A2
Iteration 4	UBR	919	904	930	919	926	851	690	528
	DBR	6495	8434	9034	8442	7577	6511	3917	1460
	UNM	6.1	6.2	6	5.9	6	6	6	5.9
	DNM	6	6	5.9	6	6	6	6.2	6.2
	Time	23	22	21	23	22	23	21	44
	Mode	A2	A2	A2	A2	A2	A2	A2	A2