

# **ETHERNETS**

## **Annex 31B Flow Control Test Suite Version 1.3**

*Technical Document*



*Last Updated: Friday, February 03, 2006 10:50am*

---

<i>Fast Ethernet Consortium</i>	<a href="http://www.iol.unh.edu/consortiums/fe">http://www.iol.unh.edu/consortiums/fe</a>
<i>Gigabit Ethernet Consortium</i>	<a href="http://www.iol.unh.edu/consortiums/ge">http://www.iol.unh.edu/consortiums/ge</a>
<i>10-Gigabit Ethernet Consortium</i>	<a href="http://www.iol.unh.edu/consortiums/10ge">http://www.iol.unh.edu/consortiums/10ge</a>

*University of New Hampshire  
InterOperability Laboratory*

*121 Technology Drive, Suite 2  
Durham, NH 03824  
Phone: +1-603-862-0090*

---

## **MODIFICATION RECORD**

- **February 3, 2006 Version 1.3 Released**  
Mike Henninger: Updated references to IEEE std. 802.3 – 2005
- **March 3, 2005 Version 1.2 Released**  
Prabesh Devkota, Mike Henninger, Jeff Lapak:
  - Modified 10Gigabit Test Suite for use by all Ethernet Consortiums
  - Fixed Typographical Errors in all tests
  - Added ANNEXES
  - Removed End-to-End Flow Control Test
- **August 18, 2003 10Gigabit Ethernet Version 1.0 Released**  
Eric Lynskey: Major rewrite of Gigabit Ethernet Testsuite
- **May 20, 2003 Gigabit Ethernet Version 1.1 Released**  
Unknown: Gigabit Ethernet organized and combined all Tests into one document.

## **ACKNOWLEDGMENTS**

**The University of New Hampshire would like to acknowledge the efforts of the following individuals in the development of this test suite.**

Rupert Dance	University of New Hampshire
Prabesh Devkota	University of New Hampshire
Adam Healey	University of New Hampshire
Mike Henninger	University of New Hampshire
Jeff Lapak	University of New Hampshire
Eric Lynskey	University of New Hampshire
Gerard Nadeau	University of New Hampshire
Robert Noseworthy	University of New Hampshire
Barry Reinhold	University of New Hampshire

## **INTRODUCTION**

### **Overview**

The University of New Hampshire InterOperability Laboratory (UNH-IOL) is an institution designed to improve the interoperability of standards based products by providing an environment where a product can be tested against other implementations of a standard. This suite of tests has been developed to help implementers evaluate the functioning of their Clause 31 and Annex 31B PAUSE based products. The tests do not determine if a product conforms to the IEEE 802.3 standard, nor are they purely interoperability tests. Successful completion of all tests contained in this suite does not guarantee that the tested device will operate with other PAUSE capable devices. However, combined with satisfactory operation in the UNH-IOL interoperability test bed, these tests provide a reasonable level of confidence that the device under test (DUT) will function well in most PAUSE capable environments.

### **Organization of Tests**

The tests contained in this document are organized to simplify the identification of information related to a test and to facilitate in the actual testing process. Each test contains an identification section that describes the test and provides cross-reference information. The discussion section covers background information and specifies why the test is to be performed. Tests are grouped in order to reduce setup time in the lab environment. Each test contains the following information:

### **Test Number**

The Test Number associated with each test follows a simple grouping structure. Listed first is the Test Group Number followed by the test's number within the group. This allows for the addition of future tests to the appropriate groups of the test suite without requiring the renumbering of the subsequent tests.

### **Purpose**

The purpose is a brief statement outlining what the test attempts to achieve. The test is written at the functional level.

### **References**

The references section lists cross-references to the IEEE 802.3 standards and other documentation that might be helpful in understanding and evaluating the test and results.

### **Resource Requirements**

The requirements section specifies the hardware, and test equipment that will be needed to perform the test. The items contained in this section are special test devices or other facilities, which may not be available on all devices.

### **Last Modification**

This specifies the date of the last modification to this test.

### **Discussion**

The discussion covers the assumptions made in the design or implementation of the test as well as known limitations. Other items specific to the test are covered here.

### **Test Setup**

The setup section describes the configuration of the test environment. Small changes in the configuration should be included in the test procedure.

### **Procedure**

The procedure section of the test description contains the step-by-step instructions for carrying out the test. It provides a cookbook approach to testing, and may be interspersed with observable results.

*The University of New Hampshire  
InterOperability Laboratory*

**Observable Results**

The observable results section lists specific items that can be examined by the tester to verify that the DUT is operating properly. When multiple values are possible for an observable result, this section provides a short discussion on how to interpret them. The determination of a pass or fail for a certain test is often based on the successful (or unsuccessful) detection of a certain observable result.

**Possible Problems**

This section contains a description of known issues with the test procedure, which may affect test results in certain situations.

## TABLE OF CONTENTS

MODIFICATION RECORD .....	ii
ACKNOWLEDGMENTS .....	iii
INTRODUCTION .....	iv
TABLE OF CONTENTS.....	vi
GROUP 1: Reception of Valid PAUSE Frames .....	7
Test #31.1.1 – Reception of PAUSE Frames .....	8
Test #31.1.2 – Reception of Multiple PAUSE Frames .....	10
Test #31.1.3 – Receive PAUSE frame with Unicast address .....	12
Test #31.1.4 – Commencement of Pause.....	13
Test #31.1.5 – Commencement of Pause while Transmitting a Frame.....	15
GROUP 2: Reception of invalid PAUSE Frames.....	16
Test #31.2.1 – Invalid MAC Control Frame Reception and Handling .....	17
Test #31.2.2 – Receive MAC Control PAUSE frames with incorrect CRC .....	19
Test #31.2.3 – Receive oversized MAC Control PAUSE frames.....	20
Test #31.2.4 – Receive runt MAC Control PAUSE frames .....	21
GROUP 3: Transmission of PAUSE Frames.....	22
Test #31.3.1 – PAUSE frame transmission.....	23
Test #31.3.2 – PAUSE frame transmission while being paused .....	24
GROUP 4: System Issues .....	25
Test #31.4.1 – Allocation of Proper Buffer Space (Informative) .....	26
Test #31.4.2 – PAUSE mode configuration .....	28
ANNEX A – Suggested Procedures for causing the DUT to Transmit PAUSE Frames .....	30
ANNEX B – Guide for configuration of flow control modes via auto-negotiation .....	31

## **GROUP 1: Reception of Valid PAUSE Frames**

**Scope:** The following tests cover Flow Control operations upon the reception of valid PAUSE frames.

**Overview:** These tests observe the behavior of the DUT when it receives valid PAUSE frames. Tests 31.1.1 and 31.1.2 verify that the DUT properly ceases its transmissions for the correct amount of time. Tests 31.1.3 – 31.1.5 verify that the DUT behaves properly when different types of PAUSE frames are received and when they are received at various times.

*The University of New Hampshire  
InterOperability Laboratory*

**Test #31.1.1 – Reception of PAUSE Frames**

**Purpose:** To verify that the device under test (DUT) inhibits the transmission of MAC client frames when a PAUSE frame is received.

**References:**

- [1] IEEE Std 802.3-2005 - Subclauses 31.3 and 31B.3.3

**Resource Requirements:**

- A testing station capable of encoding (decoding) data supplied from (to) the MAC and sending (receiving) these code groups using the appropriate signaling methods.

**Last Modification:** February 3, 2006

**Discussion:** MAC Control sublayers implementing the PAUSE function incorporate a timer called `pause_timer`. When `pause_timer` is non-zero, the MAC Control sublayer inhibits the transmission of frames by the MAC client. The timer counts down, in real time, to zero at which point the transmission of frames by the MAC client may continue.

When a MAC Control frame indicating the PAUSE function, henceforth referred to as a PAUSE frame, is received, the MAC Control sublayer checks the Destination Address field. If it is the unique address of the station or the multicast address reserved for PAUSE transactions (01-80-C2-00-00-01), `pause_timer` is set to  $n\_quanta\_rx * pause\_quantum$  where `n_quanta_rx` is the received value of how many `pause_quantum` to cease transmissions, and `pause_quantum` is defined to be 512 bit times. For example, if `n_quanta_rx` (also known as `pause_time`) were 0x000A, then `pause_timer` should be set to 5,120 bit times. For a Fast Ethernet implementation, this would correspond to 51.2µs, whereas for Gigabit Ethernet, this would correspond to 5.12µs, and 0.512µs for 10-Gigabit Ethernet. Otherwise, the MAC Control sublayer waits for the next frame to be received.

Zero is also a valid value for `pause_time`. If a PAUSE frame is received with `pause_time` set to zero, it enables the recipient to resume transmission of MAC Client frames if `pause_timer` was non-zero. If `pause_timer` were already zero, such a frame should have no effect.

The DUT may be capable of supporting multiple flow control modes. The flow control mode that allows both the generation and reception of PAUSE frames is called symmetric flow control. The flow control mode that allows either just generation or just reception of PAUSE frame is called asymmetric flow control (AFC). No flow control mode implies that PAUSE frames should neither be generated nor responded to. Essentially, the flow control mode dictates whether or not a device may transmit PAUSE frames and whether or not the device will honor PAUSE requests.

**Test Setup:** Using the appropriate medium (e.g. single-mode fiber, multi-mode fiber, twisted pair copper), connect the transmitter of the DUT to the receiver of the testing station and the receiver of the DUT to the transmitter of the testing station.

**Procedure:**

1. Configure the DUT to operate in any flow control mode for which PAUSE receive is enabled.
2. Transmit a PAUSE frame to the DUT while observing its effect on the transmission of frames from the DUT.
3. Repeat step 2 while varying the `pause_time` values (e.g. 0x0000, 0x8000, 0xFFFF, etc.).

**Observable results:**

- a. The DUT should inhibit the transmission of MAC Client frames for the appropriate number of `pause_quantum`, according to the value of `pause_time` in the PAUSE frame. The reception of a PAUSE frame shall not interfere with a transmission in progress. The DUT should not begin a new MAC Client transmission before `pause_quantum` bit times (measured at the MII or GMII) following the reception of the PAUSE frame.



*The University of New Hampshire  
InterOperability Laboratory*

**Possible Problems:**

- The gap between consecutive frames may not be constant. This could make it difficult for the effect of the PAUSE frame to be assessed.

*The University of New Hampshire*  
*InterOperability Laboratory*

**Test #31.1.2 – Reception of Multiple PAUSE Frames**

**Purpose:** To verify that the device under test (DUT) either resumes the transmission of or continues to inhibit transmission of MAC Client frames when `pause_timer` is non-zero and it receives an additional PAUSE frame.

**References:**

- [1] IEEE Std 802.3-2005 - Subclauses 31.3, 31B.3.3, and 31B.3.7

**Resource Requirements:**

- A testing station capable of encoding (decoding) data supplied from (to) the MAC and sending (receiving) these code groups using the appropriate signaling methods.

**Last Modification:** February 3, 2006

**Discussion:** MAC Control sublayers implementing the PAUSE function incorporate a timer called `pause_timer`. When `pause_timer` is non-zero, the MAC Control sublayer inhibits the transmission of frames by the MAC client. The timer counts down, in real time, to zero at which point the transmission of frames by the MAC client may continue.

When a MAC Control frame indicating the PAUSE function, henceforth referred to as a PAUSE frame, is received, the MAC Control sublayer checks the Destination Address field. If it is the unique address of the station or the multicast address reserved for PAUSE transactions (01-80-C2-00-00-01), `pause_timer` is set to `pause_time pause_quantum` where `pause_quantum` is defined to be 512 bit times. For example, if `pause_time` were 0x000A, then `pause_timer` would be set to 5,120 bit times (which would correspond to 51.2µs for Fast Ethernet implementation, 5.12µs for Gigabit Ethernet, and 0.512µs for 10-Gigabit Ethernet implementation). Otherwise, the MAC Control sublayer waits for the next frame to be received.

The reception of a valid MAC Control frame with the opcode indicating PAUSE and the Destination Address indicating the multicast address reserved specified in 31B.1(a) or the unique physical address associated with this station should cause the `pause_timer` to be set according to the `pause_time request_operand` in the newly received frame, regardless of the current setting of the `pause_timer`, i.e., new PAUSE operations override earlier PAUSE operations.

**Test Setup:** Using the appropriate medium (e.g. single mode fiber, multi-mode fiber, twisted pair, copper), connect the transmitter of the DUT to the receiver of the testing station and the receiver of the DUT to the transmitter of the testing station.

**Procedure:**

1. Configure the DUT to operate in any flow control mode for which PAUSE receive is enabled.
2. Instruct the testing station to transmit a valid PAUSE frame to the DUT with `pause_time` set to 0xFFFF.
3. Before `pause_timer` expires, and at a known time *x* (for example 0x3FFF `pause_quantum` or 8,388,096 bit times), instruct the testing station to transmit a PAUSE frame to the DUT with `pause_time` set to zero.
4. Observe the effect of the second PAUSE frame on the transmission of the frames from the DUT.
5. Repeat steps 1-4 changing the `pause_time` to 0xFFFF in step 3.
6. Repeat steps 1-4 changing the `pause_time` to 0x7FFF in step 3.

**Observable results:**

- a. Upon reception of the PAUSE frame with `pause_timer` set to 0x0000 in step 4, the DUT should resume transmission of MAC Client frames after reception of the second PAUSE frame (if *x* = 0x3FFF `pause_quantum`, the device should pause transmission for 0x3FFF `pause_quantum`).
- b. Upon reception of the PAUSE frame with `pause_timer` set to 0xFFFF in step 4, the DUT should continue to inhibit the transmission of MAC Client frames for a total pause time of *x* + 0xFFFF `pause_quantum` (if *x* = 0x3FFF the DUT should inhibit the transmission of MAC Client frames for 0x13FFE `pause_quantum`).

*The University of New Hampshire  
InterOperability Laboratory*

- c. Upon reception of the PAUSE frame with `pause_timer` set to `0x7FFF` in step 4, the DUT should continue to inhibit the transmission of MAC Client frames for a total pause time of  $x + 0x7FFF \text{ pause\_quantum}$  (if  $x = 0x3FFF$  the DUT should inhibit the transmission of MAC Client frames for `0xBFFE pause_quantum`).

**Possible Problems:**

- As the interpacket gap between the data frames approaches `0xFFFF`, it becomes increasingly more difficult to assess the affects of the PAUSE frames. If the PAUSE frame with `pause_time` set to zero is transmitted too early, the entire PAUSE transaction will be indistinguishable from normal inter\_packet gap. If the frame is transmitted too late, it will be unclear if the frame enabled transmissions due to the reception of a PAUSE frame with `pause_time` equal to zero or if `pause_timer` simply expired. Note that the time it takes for the DUT to enable the transmission of MAC Client frames after `pause_timer` expires is unspecified.
- There is a maximum delay of 1 `pause_quantum` bit times at the MII for Fast Ethernet implementations, 2 `pause_quantum` bit times at the MDI for Gigabit Ethernet implementations and 60 `pause_quantum` bit times at the MDI for 10-Gigabit Ethernet implementations from when the DUT receives a valid PAUSE frame until it is acted on. This delay should be taken into account when measuring the total time a device pauses.
- It might be difficult to measure the exact amount of time (in `pause_quantum`) between the transmission of the two PAUSE frames.

*The University of New Hampshire  
InterOperability Laboratory*

**Test #31.1.3 – Receive PAUSE frame with Unicast address**

**Purpose:** To verify that the device under test (DUT) inhibits the transmission of MAC client frames when a PAUSE frame with the Destination Address set to the unicast address of the DUT is received.

**References:**

- [1] IEEE Std 802.3-2005 - Subclauses 31.3 and 31B.3.3

**Resource Requirements:**

- A testing station capable of encoding (decoding) data supplied from (to) the MAC and sending (receiving) these code groups using the appropriate signaling methods.

**Last Modification:** February 3, 2006

**Discussion:** MAC Control sublayers implementing the PAUSE function incorporate a timer called `pause_timer`. When `pause_timer` is non-zero, the MAC Control sublayer inhibits the transmission of frames by the MAC client. The timer counts down, in real time, to zero at which point the transmission of frames by the MAC client may continue.

When a MAC Control frame indicating the PAUSE function, henceforth referred to as a PAUSE frame, is received, the MAC Control sublayer checks the Destination Address field. If it is the unique address of the station or the multicast address reserved for PAUSE transactions (01-80-C2-00-00-01), `pause_timer` is set to `pause_time pause_quantum` where `pause_quantum` is defined to be 512 bit times.

**Test Setup:** Using the appropriate medium (e.g. single mode fiber, multi-mode fiber, twisted pair copper), connect the transmitter of the DUT to the receiver of the testing station and the receiver of the DUT to the transmitter of the testing station.

**Procedure:**

1. Configure the DUT to operate in any of its available flow control modes in which PAUSE receive is enabled.
2. Transmit a PAUSE frame with the Destination Address equal to the unicast address of the DUT to the DUT while observing its effect on the transmission of frames from the DUT.

**Observable results:**

- a. Upon reception of the PAUSE frame with Destination Address set to the unicast address of the DUT, the DUT should inhibit the transmission of MAC Client frames for `pause_time pause_quantum`.

**Possible Problems:**

- The gap between consecutive frames may not be constant. This could make it difficult for the effect of the PAUSE frame to be assessed.
- It may not be possible to determine the unicast address of the DUT.

*The University of New Hampshire  
InterOperability Laboratory*

**Test #31.1.4 – Commencement of Pause**

**Purpose:** To verify that the DUT shall not begin to transmit a new MAC Client frame more than the allowable number of pause\_quantum bit times after the reception of a valid PAUSE frame that contains a non-zero value of pause\_time, as measured at the MDI.

**References:**

- [1] IEEE Std 802.3-2005 - Subclause 31B.3.7

**Resource Requirements:**

- A testing station capable of encoding (decoding) data supplied from (to) the MAC and sending (receiving) these code groups using the appropriate signaling methods.

**Last Modification:** February 3, 2006

**Discussion:** In full duplex mode, it is possible to receive PAUSE frames asynchronously with respect to the transmission of MAC Client frames. For effective flow control, it is necessary to place an upper bound on the length of time that a device can transmit MAC Client frames after receiving a valid PAUSE frame with a non-zero pause\_time request\_operand.

Reception of a PAUSE frame should not affect the transmission of a frame that has been submitted by the MAC Control sublayer to the underlying MAC (i.e., the TransmitFrame function is synchronous, and is never interrupted).

At operating speeds of 100Mb/s or less, a station that implements an exposed MII, should not begin to transmit a new frame more than pause\_quantum bit times after the reception of a valid PAUSE frame that contains a non-zero value of pause\_time; for operating speeds of 100Mb/s or less without an exposed MII this value increases to pause\_quantum + 64 bit times, as measured at the MDI. This value increases to 2 pause\_quantum bit times for operating speeds of 1000Mb/s or 10/100Mb/s devices without an exposed MII, and to 60 pause\_quantum bit times for operating speeds of 10,000Mb/s, as measured at the MDI.

**Test Setup:** Using the appropriate medium (e.g. single mode fiber, multi-mode fiber, twisted pair copper), connect the transmitter of the DUT to the receiver of the testing station and the receiver of the DUT to the transmitter of the testing station.

**Procedure:**

1. Configure the DUT to operate in any of its available flow control modes in which PAUSE receive is enabled.
2. Force the DUT to transmit two frames, each separated by a minimum IPG.
3. Transmit a PAUSE frame to the DUT with a pause\_time of 0xFFFF, so that it is completely received during the first byte of idle between the two frames.
4. Increase the amount of IPG between each frame by one byte and repeat steps 1 through 3 until the DUT is observed to PAUSE before transmitting the second frame. Typically, due to time limitations it will be necessary to increase the amount of IPG between each frame by more than one byte.

**Observable results:**

- a. The DUT shall inhibit the second frame before the IPG is equal to:

Speed	Maximum IPG
10/100Mb/s with exposed MII	65 bytes
10/100Mb/s without exposed MII	73 bytes
1000Mb/s	129 bytes
10,000Mb/s	3,841 bytes

**Possible Problems:**

- The testing station must be capable of sending a frame so that it is completely received during the first byte of IFG. If the testing station does not have this type of precision, it will be necessary to include the tolerances of the testing station so that the accuracy of the test can be determined.

*The University of New Hampshire  
InterOperability Laboratory*

- It is often difficult to force devices to transmit frames separated by a specific amount of idle (in particular DTEs), which could make this test impossible to do.

### **Test #31.1.5 – Commencement of Pause while Transmitting a Frame**

**Purpose:** To verify that the reception of a PAUSE frame and the commencement of pause by the device under test (DUT) does not interfere with a transmission in progress.

**References:**

- [1] IEEE Std 802.3-2005 - Subclause 31B.3.7

**Resource Requirements:**

- A testing station capable of encoding (decoding) data supplied from (to) the MAC and sending (receiving) these code groups using the appropriate signaling methods.

**Last Modification:** February 3, 2006

**Discussion:** MAC Control sublayers implementing the PAUSE function incorporate a timer called `pause_timer`. When `pause_timer` is non-zero, the MAC Control sublayer inhibits the transmission of frames by the MAC client. The timer counts down, in real time, to zero at which point the transmission of frames by the MAC client may continue.

When a MAC Control frame indicating the PAUSE function, henceforth referred to as a PAUSE frame, is received, the MAC Control sublayer checks the Destination Address field. If it is the unique address of the station or the multicast address reserved for PAUSE transactions (01-80-C2-00-00-01), `pause_timer` is set to `pause_time` `pause_quantum` where `pause_quantum` is defined to be 512 bit times.

At operating speeds of 100Mb/s or less, a station that implements an exposed MII, should not begin to transmit a new frame more than `pause_quantum` bit times after the reception of a valid PAUSE frame that contains a non-zero value of `pause_time`; for operating speeds of 100Mb/s or less without an exposed MII this value increases to `pause_quantum` + 64 bit times, as measured at the MDI. This value increases to 2 `pause_quantum` bit times for operating speeds of 1000Mb/s or 10/100Mb/s devices without an exposed MII, and to 60 `pause_quantum` bit times for operating speeds of 10,000Mb/s, as measured at the MDI.

Since the reception of a PAUSE frame cannot interfere with a transmission in progress, the device is constrained to not begin the transmission of a new frame after it receives a PAUSE frame, but must finish transmitting the current frame.

**Test Setup:** Using the appropriate medium (e.g. single mode fiber, multi-mode fiber, twisted pair copper), connect the transmitter of the DUT to the receiver of the testing station and the receiver of the DUT to the transmitter of the testing station.

**Procedure:**

1. Configure the DUT to operate in any of its available flow control modes in which PAUSE receive is enabled.
2. Instruct the testing station to transmit a validly formed PAUSE frame with a non-zero `pause_time`.
3. Force the DUT to transmit two frames so that pause commences (use the value determined in Test #31.1.4 – Commencement of Pause) during the transmission of the first frame.

**Observable results:**

- a. The DUT should inhibit the transmission of frames for `pause_time` after the completion of the first frame. The reception of the PAUSE frame shall not interfere with a transmission in progress.

**Possible Problems:**

- Care must be taken to assure that the DUT commences pause while it is still transmitting a data frame. This could be helped by forcing the DUT to transmit frames that are 1518 bytes in length.

## **GROUP 2: Reception of invalid PAUSE Frames**

**Scope:** The following tests cover Flow Control operations upon the reception of invalid PAUSE frames.

**Overview:** These tests observe the behavior of the DUT when it receives invalid PAUSE frames. Tests 31.2.1 and 31.2.2 verify that the DUT behaves properly upon the reception of PAUSE frames that contain errors. Tests 31.2.3 and 31.2.4 verify the behavior of the DUT upon reception of PAUSE frames of various sizes.



*The University of New Hampshire  
InterOperability Laboratory*

**Test #31.2.1 – Invalid MAC Control Frame Reception and Handling**

**Purpose:** To verify that the device under test (DUT) rejects invalid MAC Control PAUSE frames.

**References:**

- [1] IEEE Std 802.3-2005 - Subclauses 3.5, 31.4, 31.5.1, and 31.5.2

**Resource Requirements:**

- A testing station capable of encoding (decoding) data supplied from (to) the MAC and sending (receiving) these code groups using the appropriate signaling methods.

**Last Modification:** February 3, 2006

**Discussion:** The Destination Address field of a MAC Control frame contains the 48-bit address of the station(s) for which the frame is intended. It may be an individual or multicast (including broadcast) address. Permitted values for the Destination Address field may be specified separately for each MAC Control opcode in the annexes to Clause 31. Specifically, for a PAUSE frame, the Destination Address field must be set to the multicast address reserved for PAUSE operation (01-80-C2-00-00-01), though a device should also be capable of receiving PAUSE frames containing the unicast address of the device.

Each MAC Control frame is encapsulated by the MAC and should contain a valid FCS. MAC Control frames are distinguished from MAC Client frames only by their Length/Type field identifier. For MAC Control frames, the Length/Type field must be set to 0x8808. Upon receipt, the MAC Control sublayer parses the incoming frame to determine whether it is destined for the MAC client (Data frame) or for a specific function within the MAC Control sublayer entity itself (MAC Control frame). MAC Control frames with a length of minFrameSize and a supported opcode field are interpreted and acted upon by the MAC Control sublayer. A frame that does not contain the unique Length/Type field specified in 31.4.1.3 is a Data frame. If a PAUSE frame contains a VLAN tag it will be seen as a data frame because it will be seen as having a Length/Type value of 0x8100.

Validly received MAC Control frames are further parsed to determine the opcode. The opcode is contained in the first two octets of the dataParam from the Receive Frame function. Valid values for this field are contained in Annex 31A (hexadecimal values from 0x0001 to 0x0007 are currently defined whereas 0x0000 and 0x0008 to 0xFFFF are reserved), and the value for a PAUSE frame is the hexadecimal value of 0x0001. If the MAC Control sublayer entity supports the function requested by the specified opcode, it interprets and acts upon the MAC Control frame in an opcode and request\_operand-specific manner. If the MAC Control sublayer entity does not support the function requested by the specified opcode, it discards the MAC Control frame. Discarding a MAC Control frame in this manner may be reported to network management.

Thus the MAC Control sublayer will only act on PAUSE frames that have the unicast address of the station or the multicast address reserved for PAUSE operations (01-80-C2-00-00-01), a Length/Type field equal to 88-08, and an opcode of 00-01.

<b>Label</b>	<b>Description</b>
Test Frame 1	An otherwise properly encapsulated MAC Control PAUSE frame with Destination Address that is not the well-known multicast address (01-80-C2-00-00-01) or unicast address of the DUT. Possible values of the Destination Address may include but are not limited to a unicast address different than that of the DUT, a broadcast address, and a multicast address different than the well-known multicast address listed above.
Test Frame 2	An otherwise properly encapsulated MAC frame with Length/Type not equal to 88-08. Several Length/Type values, including 88-09 and 00-2E shall be tested.
Test Frame 3	An otherwise properly encapsulated MAC Control frame with the opcode not equal to 00-01. Opcode values 00-02 to 00-07 and several reserved opcode values shall be tested.
Test Frame 4	An otherwise properly encapsulated MAC Control frame with a qTag type of 0x8100 and valid Tag Control Information (as defined in Clause 3.5) inserted between the source address and the length/type field.

*The University of New Hampshire  
InterOperability Laboratory*

**Test Setup:** Using the appropriate medium (e.g. single mode fiber, multi-mode fiber, twisted pair copper), connect the transmitter of the DUT to the receiver of the testing station and the receiver of the DUT to the transmitter of the testing station.

**Procedure:**

1. Configure the DUT to operate in any available flow control mode with PAUSE receive enabled.
2. Transmit Test Frame 1 to the DUT while observing its effect on the transmission of valid MAC client frames from the DUT.
3. Repeat step 2 for all test frames described in the above table.

**Observable results:**

- a. The DUT should not inhibit the transmission of valid MAC client frames upon reception of a PAUSE frame that does not contain either the well-known multicast address or the unicast address of the DUT.
- b. The DUT should not inhibit the transmission of valid MAC client frames upon reception of a PAUSE frame that does not contain the hexadecimal Length/Type value of 88-08.
- c. The DUT should not inhibit the transmission of valid MAC client frames upon reception of a PAUSE frame that does not contain the hexadecimal opcode value of 00-01.
- d. The DUT should not inhibit the transmission of valid MAC client frames upon reception of a PAUSE frame with a qTag prefix inserted between the source address and the Length/Type field.

**Possible Problems:**

- The gap between consecutive frames may not be constant. This could make it difficult for the effect of the PAUSE frame to be assessed.

*The University of New Hampshire  
InterOperability Laboratory*

**Test #31.2.2 – Receive MAC Control PAUSE frames with incorrect CRC**

**Purpose:** To verify that the device under test (DUT) rejects MAC control PAUSE frames with FCS errors.

**References:**

- [1] IEEE Std 802.3-2005 - Subclauses 3.2.8 and 3.4

**Resource Requirements:**

- A testing station capable of encoding (decoding) data supplied from (to) the MAC and sending (receiving) these code groups using the appropriate signaling methods.

**Last Modification:** February 3, 2006

**Discussion:** The MAC sublayer collects bits from the reconciliation layer. One of its functions is to check for invalid MAC frames by checking the Frame Check Sequence (FCS) field. It does so by computing the 32-bit CRC of the received frame and comparing it to the received 32-bit CRC in the FCS field. In case of a mismatch, the MAC sublayer should discard the frame and not forward the frame to the MAC Control sublayer.

**Test Setup:** Using the appropriate medium (e.g. balanced copper, multi-mode fiber, etc.), connect the transmitter of the DUT to the receiver of the testing station and the receiver of the DUT to the transmitter of the testing station.

**Procedure:**

1. Configure the DUT to operate in a mode with PAUSE receive enabled.
2. Transmit a PAUSE frame with an invalid CRC value in the FCS field and a pause\_time of 0xFFFF to the DUT while observing its effect on the transmission of frames from the DUT.

**Observable results:**

- a. The MAC sublayer should discard the frame and the DUT shall not inhibit the transmission of MAC Client frames due to the reception of a PAUSE frame with an invalid CRC value.

**Possible Problems:**

- The gap between consecutive frames may not be constant. This could make it difficult for the effect of the PAUSE frame to be assessed.

*The University of New Hampshire  
InterOperability Laboratory*

**Test #31.2.3 – Receive oversized MAC Control PAUSE frames**

**Purpose:** To determine how the device under test (DUT) handles PAUSE frames that are greater than minFrameSize in length.

**References:**

- [1] IEEE Std 802.3-2005 - Subclause 31.5.1

**Resource Requirements:**

- A testing station capable of encoding (decoding) data supplied from (to) the MAC and sending (receiving) these code groups using the appropriate signaling methods.

**Last Modification:** February 3, 2006

**Discussion:** The MAC sublayer will return any received frame at least minFrameSize in length with the appropriate Destination Address when the ReceiveFrame function is called. By definition, MAC Control frames are fixed to be minFrameSize in length. The MAC Control sublayer may either discard a MAC Control frame longer than minFrameSize or truncate the frame to minFrameSize before parsing it.

**Test Setup:** Using the appropriate medium (e.g. balanced copper, multi-mode fiber, etc.), connect the transmitter of the DUT to the receiver of the testing station and the receiver of the DUT to the transmitter of the testing station.

**Procedure:**

1. Configure the DUT to operate in a flow control mode with PAUSE receive enabled.
2. Transmit a PAUSE frame longer than minFrameSize (512 bits) to the multicast address (01-80-C2-00-00-01) with pause\_time set to 0xFFFF to the DUT while observing its effect on the transmission of frames from the DUT.
3. Repeat steps 1 through 2 sending PAUSE frames of sizes including but not limited to 65, 512, 1518, 1519, and 2052 bytes.

**Observable results:**

- a. If the DUT inhibits the transmission of MAC Client frames, then we assume the MAC Control sublayer has truncated the frame to minFrameSize and parsed it. Otherwise, we assume the MAC control sublayer has discarded the frame.

**Possible Problems:**

- The gap between consecutive frames may not be constant. This could make it difficult for the effect of the PAUSE frame to be assessed.
- Frames greater than maxUntaggedFrameSize may be discarded by the MAC layer and not passed up to the MAC Control sublayer.

*The University of New Hampshire  
InterOperability Laboratory*

**Test #31.2.4 – Receive runt MAC Control PAUSE frames**

**Purpose:** To determine how the device under test (DUT) handles PAUSE frames that are less than minFrameSize in length.

**References:**

- [1] IEEE Std 802.3-2005 - Subclauses 31.5.1, 4.2.9, and 4.2.4.2.2

**Resource Requirements:**

- A testing station capable of encoding (decoding) data supplied from (to) the MAC and sending (receiving) these code groups using the appropriate signaling methods.

**Last Modification:** February 3, 2006

**Discussion:** The MAC sublayer will return any received frame at least minFrameSize in length with the appropriate Destination Address when the ReceiveFrame function is called. By definition, MAC Control frames are fixed to be minFrameSize in length. The MAC should discard any frame that is less than minFrameSize in length and not send it up to the MAC Control sublayer. Thus, MAC Control frames less than minFrameSize should never be received by the MAC Control layer and acted upon.

**Test Setup:** Using the appropriate medium (e.g. balanced copper, multi-mode fiber, twisted pair copper, etc.), connect the transmitter of the DUT to the receiver of the testing station and the receiver of the DUT to the transmitter of the testing station.

**Procedure:**

1. Configure the DUT to operate in a flow control mode with PAUSE receive enabled.
2. Transmit a PAUSE frame with length less than minFrameSize (512 bits) and pause\_time set to 0xFFFF, to the DUT while observing its effect on the transmission of frames from the DUT.
3. Repeat steps 1 through 2 sending PAUSE frames of sizes including but not limited to 22, 59, 60, and 63 bytes.

**Observable results:**

- a. The DUT should discard the PAUSE frame and the DUT shall not inhibit the transmission of MAC Client frames due to the reception of these frames.

**Possible Problems:**

- The gap between consecutive frames may not be constant. This could make it difficult for the effect of the PAUSE frame to be assessed.

## **GROUP 3: Transmission of PAUSE Frames**

**Scope:** The following tests cover Flow Control operations upon the transmission of PAUSE frames.

**Overview:** These tests verify that the DUT is capable of transmitting validly formed PAUSE frames under the appropriate conditions. Test 31.3.1 verifies that, in general, the PAUSE frames transmitted by the DUT are valid. Test 31.3.2 verifies that the DUT is still capable of transmitting MAC Control frames if it is being paused by its link partner. Test 31.3.3 verifies that the DUT does not forward PAUSE frames, as, according to Clause 31/Annex 31B, Flow Control is only intended to be used for a point-to-point link.

*The University of New Hampshire  
InterOperability Laboratory*

**Test #31.3.1 – PAUSE frame transmission**

**Purpose:** To verify that the device under test (DUT) transmits properly encapsulated PAUSE frames.

**References:**

- [1] IEEE Std 802.3-2005 - Subclause 31.4, Annex 31A, Annex 31B.1
- [2] ANNEX A – Suggested Procedures for causing the DUT to Transmit PAUSE Frames

**Resource Requirements:**

- A testing station capable of encoding (decoding) data supplied from (to) the MAC and sending (receiving) these code groups using the appropriate signaling methods.

**Last Modification:** February 3, 2006

**Discussion:** The MAC Control sublayer may issue a PAUSE frame at any time with any `pause_time` value it chooses. The Destination Address is required to be the multicast address reserved for PAUSE transactions. PAUSE transactions may only occur between two devices on a full-duplex network. The use of a well-known multicast address allows the devices to issue PAUSE frames without having to first discover the address of the intended recipient. The use of a multicast address also prevents 802.1D-conformant bridges from forwarding PAUSE frames to the rest of the network. A PAUSE frame that is forwarded will be seen as being an invalid PAUSE frame transmitted by the DUT. This is because the Source Address of the forwarded frame will be equal to the unicast address of the testing station and not that of the DUT.

In this test, the DUT might need to be stressed so that the receive buffers are placed in danger of overflowing. In other cases, the DUT might be capable of transmitting a PAUSE frames by other means, such as a command.

**Test Setup:** Using the appropriate medium (e.g. single mode fiber, multi-mode fiber), connect the transmitter of the DUT to the receiver of the testing station and the receiver of the DUT to the transmitter of the testing station.

**Procedure:**

1. Configure the DUT to operate in any flow control mode for which PAUSE transmit is enabled.
2. The DUT is caused to transmit a PAUSE frame by any means. Refer to ANNEX A – Suggested Procedures for causing the DUT to Transmit PAUSE Frames, for details on possible procedures to cause the DUT to transmit PAUSE frames.
3. If the DUT is a DCE, transmit a valid 64 byte PAUSE frame with the source address equal to the MAC of the testing station to one port on the DUT. Observe the transmission on one or more other ports.

**Observable results:**

- a. Given that the DUT issued a PAUSE frame, that frame should meet all of the requirements of Clause 31, Annex 31A, and Annex 31B.
- b. The PAUSE frame transmitted to the DUT should not be forwarded out any other port on the DUT.

**Possible Problems:**

- The DUT is not required to transmit PAUSE frames even if it is unable to handle the current volume of received frames. It maybe possible, in some instances, to force the DUT to transmit PAUSE frames by sending frames separated by less than minimum IPG or by shrinking the preamble. It may not always, however, be possible to observe the transmission of PAUSE frames from the DUT.

*The University of New Hampshire  
InterOperability Laboratory*

**Test #31.3.2 – PAUSE frame transmission while being paused**

**Purpose:** To verify that the ability of the device under test (DUT) to transmit properly encapsulated PAUSE frames is not inhibited by the receive PAUSE operation.

**References:**

- [1] IEEE Std 802.3-2005 - Annex 31B.1

**Resource Requirements:**

- A testing station capable of encoding (decoding) data supplied from (to) the MAC and sending (receiving) these code groups using the appropriate signaling methods.

**Last Modification:** February 3, 2006

**Discussion:** The MAC Control sublayer may issue a PAUSE frame at any time with any `pause_time` value it chooses. The Destination Address is required to be the multicast address reserved for PAUSE transactions. PAUSE transactions may only occur between two devices on a full-duplex network. The use of a well-known multicast address allows the devices to issue PAUSE frames without having to first discover the address of the intended recipient. The use of a multicast address also prevents 802.1D-conformant bridges from forwarding PAUSE frames to the rest of the network.

It is clearly stated in the Standard that the PAUSE operation shall not inhibit the ability of a device to transmit MAC Control frames. In this test, we will attempt to force the DUT to issue PAUSE frames by stressing the DUT while it is being paused. This is done in an attempt to place the receive buffers in danger of overflowing.

**Test Setup:** Using the appropriate medium (e.g. single-mode fiber, multi-mode fiber, twisted pair copper), connect the transmitter of the DUT to the receiver of the testing station and the receiver of the DUT to the transmitter of the testing station.

**Procedure:**

1. Configure the DUT to operate in a flow control mode for which PAUSE transmit and receive are enabled.
2. Instruct the testing station to transmit PAUSE frames to the DUT so that the DUT is continuously paused.
3. The DUT is caused to transmit a PAUSE frame by any means. Refer to ANNEX A – Suggested Procedures for causing the DUT to Transmit PAUSE Frames for details on the possible procedures to get the DUT to transmit PAUSE frames. If PAUSE frames were observed in test #31.3.1, then a similar procedure can be followed to generate PAUSE frames.

**Observable results:**

- a. While being paused, the DUT may transmit a PAUSE frame; that PAUSE frame shall meet all of the requirements of Clause 31, Annex 31A, and Annex 31B.

**Possible Problems:**

- The DUT is not required to transmit PAUSE frames even if it is unable to handle the current volume of received frames and it is being paused. As a result it may not always be possible to observe the transmission of PAUSE frames from the DUT.



## **GROUP 4: System Issues**

**Scope:** The following tests cover Flow Control operations with respect to system-level issues.

**Overview:** Test 31.4.1, which is informative, attempts to verify that the DUT is able to buffer frames received after it has transmitted a PAUSE frame. The behavior of the DUT, while strictly informative, can nonetheless provide valuable information on the effectiveness of the DUT's implementation of Flow Control using the PAUSE mechanism. Test 31.4.2 verifies that the DUT functions properly in all supported flow control modes.

*The University of New Hampshire  
InterOperability Laboratory*

**Test #31.4.1 – Allocation of Proper Buffer Space (Informative)**

**Purpose:** To observe if the device under test (DUT) allocates enough buffer space such that when it transmits a PAUSE frame, it will not need to discard frames that are in the process of being sent by its link partner before the link partner receives and responds to the PAUSE frame.

**References:**

- [1] IEEE Std 802.3-2005 - Subclause 31B.3.7
  - o 10Mb/s: IEEE Std 802.3-2002 - Subclause 14.1.1.1
  - o 100Mb/s: IEEE Std 802.3-2002 – Subclauses 25.4.6, 26.1
  - o 1000Mb/s: IEEE Std 802.3-2002 – Subclauses 38.3, 38.4, 40.1.1
  - o 10,000Mb/s: IEEE Std 802.3ae-2002 – Subclause 52.6

**Resource Requirements:**

- A testing station capable of encoding (decoding) data supplied from (to) the MAC and sending (receiving) these code groups using the appropriate signaling methods.

**Last Modification:** February 3, 2006

**Discussion:** When its Link Partner is overwhelming a DUT, it may send the Link Partner a PAUSE frame. From the time that the DUT sends the PAUSE frame until the time that the Link Partner stops transmitting new frames and pauses, it is possible that the Link Partner could have already sent several more frames to the DUT. One possible implementation of the DUT would be to send a PAUSE frame before its input buffers were full. To ensure that the buffer is not overfilled and that frames are not lost, the DUT must have enough buffer space to hold all of the incoming frames that could be on the medium and that could be transmitted before the Link Partner (assuming compliance) pauses. If there is enough buffer space and if the DUT sends out PAUSE frames properly, then none of the frames in the point-to-point link between the DUT and Link Partner will be dropped. The purpose of this test is to see, informatively, if the DUT possesses such buffer space, and to observe the manner in which the DUT transmits PAUSE frames.

At operating speeds of 100Mb/s or less, a station that implements an exposed MII, should not begin to transmit a new frame more than pause\_quantum bit times after the reception of a valid PAUSE frame that contains a non-zero value of pause\_time. This value increases to 1 pause\_quantum + 60 bit times for operating speeds of 10/100Mb/s devices without an exposed MII, 2 pause\_quantum for operating speeds of 1000Mb/s, and to 60 pause\_quantum bit times for operating speeds of 10,000Mb/s, as measured at the MDI.

Additionally, the length of the media (fiber, copper, etc.) between the DUT and Link Partner has a tremendous impact on the amount of data that may need to be buffered. This test does not attempt to determine the length of the cable plant that can be supported by the DUT such that no frames are lost on the link. Instead a predetermined cable plant or a simulation of such a cable plant is used for this test. The table below lists the media type, maximum length and maximum number of bytes received after the transmission of a PAUSE frame for a select set of technologies.

Technology	Medium	Length (propagation)	Maximum # of bytes possible*
10BASE-T	CAT3 UTP	100 meters (9.5 bt)	1651.125
100BASE-TX	CAT5 UTP	100 meters (95 bt)	1661.875
100BASE-FX	62.5 μm MMF	400 meters (400 bt)	1700
1000BASE-T	CAT5 UTP	100 meters (952 bt)	1825
1000BASE-SX	62.5 μm MMF, 50μm MMF	220-275 meters, 500-550 meters (5,500 bt)	2393.5
1000BASE-LX	62.5μm MMF, 50μm MMF, 10μm SMF	550 meters, 550 meters, 5000 meters (50,000 bt)	7,856 (removed 100 bytes for preamble and IFG)
10,000BASE-LR	Type B1.1, B1.3 SMF	10 km (1,000,000 bt)	~128,738 (removed 1,680 bytes for preamble and IPG)

*The University of New Hampshire  
InterOperability Laboratory*

\*Note that the reception of a PAUSE frame does not interfere with frames currently being transmitted. The number of bytes includes the delay of a maximum length cable, the 64 byte PAUSE frame (with SFD and Preamble) transmitted by the DUT, 1 pause\_quantum +60, 2 pause\_quantum or 60 pause\_quantum bit times (the maximum time between the complete reception of a PAUSE frame and the commencement of pause) and a 1518 byte frame (which the testing station could begin transmitting 1 byte before the commencement of pause).

**Test Setup:** Using the appropriate medium (e.g. balanced copper, multi-mode fiber), connect the transmitter of the DUT to the receiver of the testing station and the receiver of the DUT to the transmitter of the testing station.

**Procedure:**

1. Force the DUT to transmit a PAUSE frame, see ANNEX A – Suggested Procedures for causing the DUT to Transmit PAUSE Frames for more details.
2. Once the testing station completely receives a PAUSE frame from the DUT it is instructed to transmit the sequence described in the table below:

<b>Technology</b>	<b>Test Sequence*</b>
10BASE-T	a 105 byte frame, a 1518 byte frame
100BASE-TX	a 115 byte frame, a 1518 byte frame
100BASE-FX	a 154 byte frame, a 1518 byte frame
1000BASE-T	a 279 byte frame, a 1518 byte frame
1000BASE-SX	a 847 byte frame, a 1518 byte frame
1000BASE-LX	a 158 byte frame, 5 1518 byte frames
10,000BASE-LR	a 1,076 byte frame, 83 1518 byte frames

\*Note that all frames are separated by minimum interFrameGap, which is defined as 96 bit times for all speeds.

3. Observe the output and statistics of the DUT.

**Observable results:**

- a. The DUT should transmit a PAUSE frame or multiple PAUSE frames before its buffers are full. The buffers should be large enough to buffer all the frames on the medium and transmitted by the test station before it ceases transmission of MAC Client frames. If the buffers are large enough there should be little or no frame loss.

**Possible Problems:**

- It is conceivable that the DUT may not need to issue a PAUSE frame even while receiving frames with a minimum inter-packet gap. If this is the case, this test cannot be done.

*The University of New Hampshire  
InterOperability Laboratory*

**Test #31.4.2 – PAUSE mode configuration**

**Purpose:** To verify the ability of the device under test (DUT) to be properly configured with various flow control modes.

**References:**

- [1] IEEE Std 802.3-2005 - Annex 31B.

**Resource Requirements:**

- A testing station capable of encoding (decoding) data supplied from (to) the MAC and sending (receiving) these code groups using the appropriate signaling methods.

**Last Modification:** February 3, 2006

**Discussion:** The DUT may be capable of supporting multiple flow control modes. These modes are symmetric flow control (SFC), asymmetric flow control (AFC), and no flow control at all. SFC implies that PAUSE frames may flow in either direction. AFC implies that PAUSE frames may only flow in one direction, whether that direction is towards the local device or away from the local device. No flow control implies that PAUSE frames are not allowed. Essentially, the flow control mode dictates whether or not a device may transmit PAUSE frames and whether or not the device will honor PAUSE requests.

This test verifies that a device acts appropriately according to the current flow control settings and that management configuration settings do what they advertise. Flow control modes may be configured via auto-negotiation or through manual configuration. It should be noted that to establish a 1000BASE-T link auto-negotiation is required; thus auto-negotiation will need to be used to configure flow control settings for 1000BASE-T devices.

If auto-negotiation is used, bits D7 and D8 in the auto-negotiation base page transmitted by the DUT will determine what flow control modes are available. The testing station will send specific values in bits D7 and D8 of its own base page to enable each available mode. ANNEX B – Guide for configuration of flow control modes via auto-negotiation is provided as guide for configuring Flow Control settings on both the DUT and the Testing Station.

Given the advertised abilities of the DUT, a limited number of the flow control modes may be configured through auto-negotiation. Manual configuration may lend more flexibility but this flexibility and the procedure used to perform such configuration is device dependent.

**Test Setup:** Using the appropriate medium (e.g. single-mode fiber, multi-mode fiber, twisted pair copper), connect the transmitter of the DUT to the receiver of the testing station and the receiver of the DUT to the transmitter of the testing station.

**Procedure:**

1. Configure the DUT to operate in any of its advertised flow control modes, and, if auto-negotiation is enabled, making sure it negotiates its abilities accordingly with the testing station (this can be done by restarting auto-negotiation). See ANNEX B – Guide for configuration of flow control modes via auto-negotiation for information on how to configure the testing station.
2. Observe the behavior of the DUT while operating in the mode that has been selected using methods described in test 31.1.1 and 31.3.1.
3. Observe the status and configuration settings of the DUT.
4. Repeat steps 1 – 3 for all available flow control modes (symmetric, asymmetric toward DUT, asymmetric away from DUT, none).

**Observable results:**

- a. The DUT should operate according to the proper configurations and should display the proper status. The following is a list of the configurations and the observable results.

<b>Configurations</b>	<b>Acceptable Results</b>
Transmit and Receive PAUSE	The DUT should pause and may transmit PAUSE frames

*The University of New Hampshire  
InterOperability Laboratory*

Receive PAUSE	The DUT should inhibit transmission of MAC frames upon reception of valid PAUSE frames, however, the DUT should not transmit PAUSE frames.
Transmit PAUSE	The DUT should not inhibit the transmission of valid MAC frames upon reception of valid PAUSE frame, however, the DUT may transmit valid PAUSE frames.
None	The DUT should neither inhibit the transmission of valid MAC frames upon reception of valid PAUSE frames or transmit valid PAUSE frames to the link partner.

**Possible Problems:**

- The DUT may not have the ability to change its configuration or display its current status.
- The DUT is not required to transmit PAUSE frames even if it is unable to handle the current volume of received frames and it is being paused. As a result it may not always be possible to observe the transmission of PAUSE frames from the DUT.

## ANNEX A – Suggested Procedures for causing the DUT to Transmit PAUSE Frames

If the device has more than one port, connect two of the ports to two testing stations. Make sure that the connection between the DUT and Testing Station 1 is at a lower speed than that being tested. (e.g., if testing is being done at 1000Mb/s, connect the port and testing station at a 100Mb/s or 10Mb/s) The connection between the DUT and Testing Station 2 should be the speed being tested. This is diagramed below. Transmit frames at line rate from Testing Station 2 to Testing Station 1. The DUT will not be able to forward all the frames to Testing Station 1, so it may attempt to pause the transmission of Testing Station 2 to eliminate frame loss.

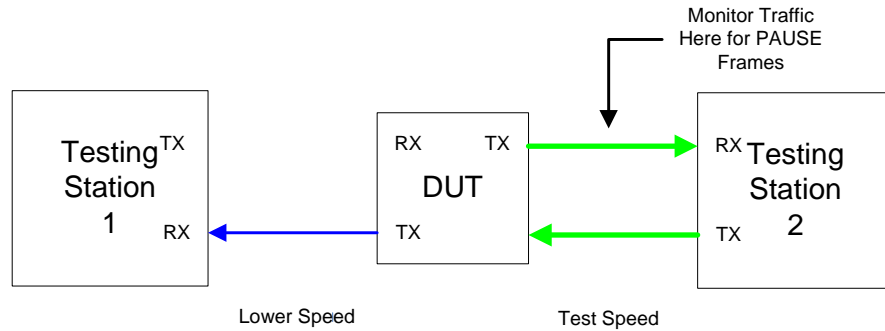

If the device has more than two ports, connect three of the ports to testing stations. Have Testing Station 1 and Testing Station 2 transmit frames at line rate to Testing Station 3. The DUT will not be able to forward all the frames to Testing Station 3, so it may attempt to pause the transmission of Testing Station 1 and Testing Station 2.

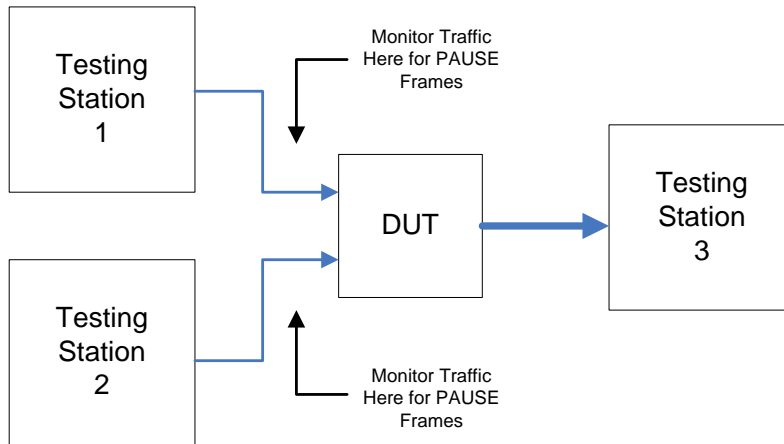

For an end station, the DUT may require a long period of time to reply to frames. Valid frames transmitted at minimum interframe gap could fill the buffers of the DUT, forcing it to transmit PAUSE frames. Another option for filling the DUT's buffers is to send frames separated by less than minimum IFG or to send frames with less than seven bytes of preamble. These options are not, however, supported by all testing stations.

## ANNEX B – Guide for configuration of flow control modes via auto-negotiation

DUT Target	DUT advertises...		Testing station advertises...	
Configuration	PAUSE	ASM_DIR	PAUSE	ASM_DIR
Disable PAUSE Transmit Disable PAUSE Receive	0	0	X	X
	0	1	0	X
	0	1	1	0
	1	0	0	X
	1	1	0	0
Disable PAUSE Transmit Enable PAUSE Receive	0	0	—	—
	0	1	—	—
	1	0	—	—
	1	1	0	1
Enable PAUSE Transmit Disable PAUSE Receive	0	0	—	—
	0	1	1	1
	1	0	—	—
	1	1	—	—
Enable PAUSE Transmit Enable PAUSE Receive	0	0	—	—
	0	1	—	—
	1	0	1	X
	1	1	1	X

NOTE — "X" indicates value may be either 0 or 1, "—" indicates target configuration cannot be achieved.